

INFORMATION

SHIP CONCEALMENT CAMOUFLAGE INSTRUCTIONS

NAVSHIPS 250-374 • NAVY DEPARTMENT BUREAU OF SHIPS • WASHINGTON, D. C.

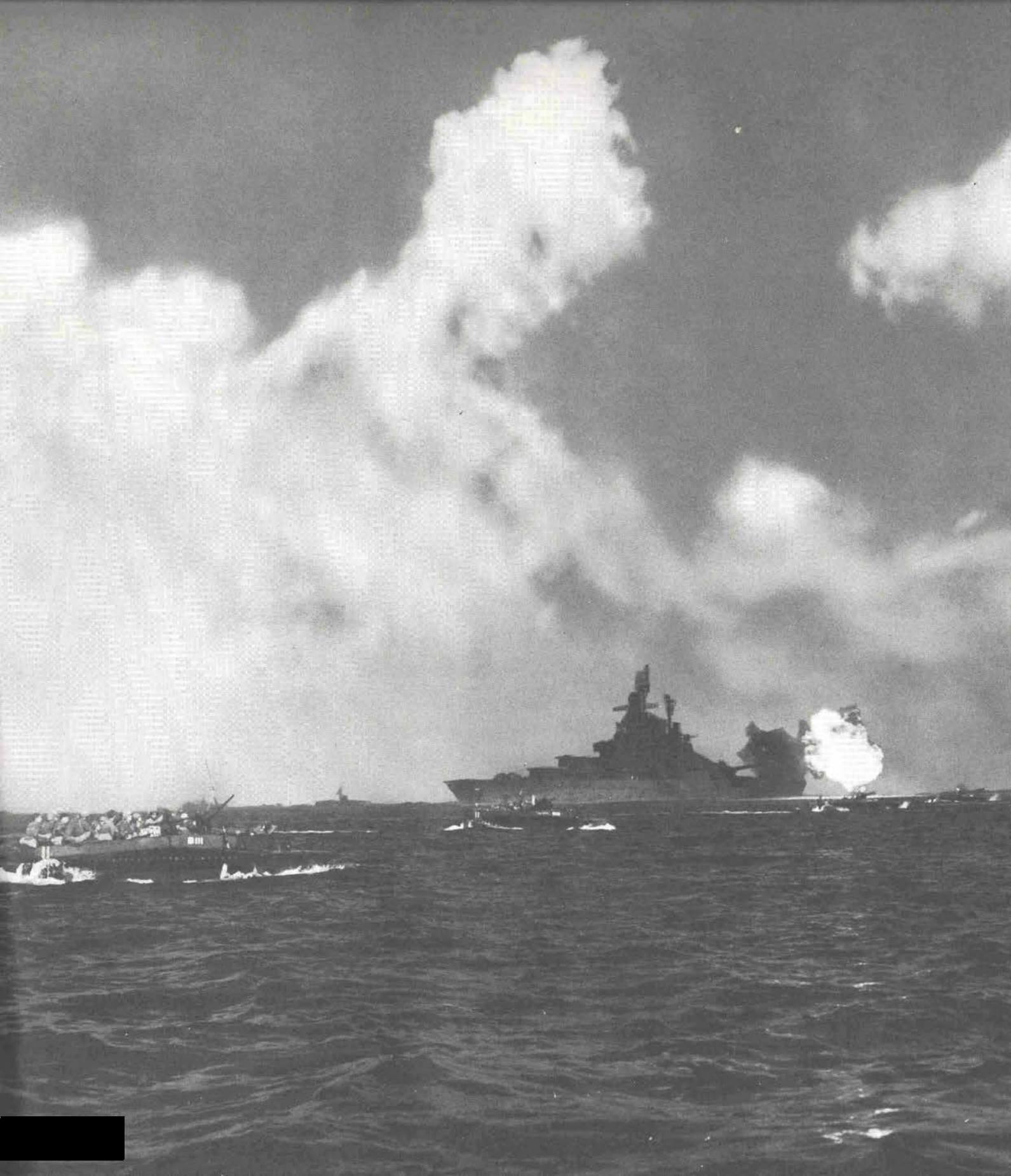



SHIP CONCEALMENT CAMOUFLAGE INSTRUCTIONS

UNITED STATES NAVY

NAVSHIPS 250-374

JANUARY 1953

P R E F A C E

This edition of Ship Concealment Camouflage Instructions U. S. Navy supersedes the following publications:

- (1) Ship Camouflage Instructions U. S. Navy (Ships-2), second revision, of June 1942;
- (2) Supplement to Ship Camouflage Instructions (Ships-2), second revision, of March 1945;
- (3) Submarine Concealment Camouflage (NavShips 250-631) of 1 August 1945.

Several of the measures contained herein are but slight modifications of measures currently in effect. A number of the measures for submarines are entirely new.

It is the responsibility of the Fleet and Force Commanders to select measures contained herein for application to vessels of their respective commands and for new vessels scheduled to join their commands and to inform the Bureau of Ships of the measures selected.

It is the responsibility of the Bureau of Ships to disseminate information regarding the painting of new types of vessels to the Naval Shipyards or to the Supervisors of Shipbuilding as may be appropriate.

FOREWORD

This booklet has two primary objectives:

1. To furnish Fleet and Force Commanders with information on the effectiveness and suitability of various concealment measures, and guidance in the selection of measures most suited to a particular vessel operating in a particular area.
2. To provide the techniques whereby each field activity, or individual vessel, will be able to apply specified concealment measures without requiring outside assistance.

To achieve the subtle concealment effects specified in the submarine measures, special painting techniques are necessary. These techniques are explained and illustrated for the first time in this publication. It is mandatory that the individual personnel directly involved in the application of submarine concealment measures be thoroughly familiar with these techniques.

The text and concealment measures illustrated in this manual are by Cdr. Dayton R. E. Brown, U. S. N., O in C Visibility and Concealment Branch, Applied Sciences Division, Bureau of Ships.

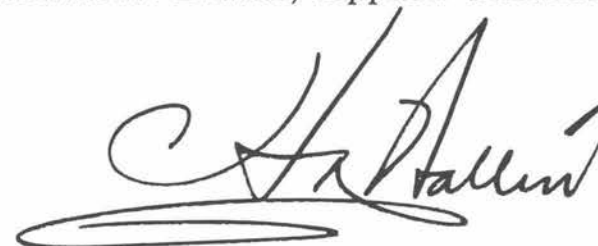

REAR ADMIRAL, U. S. N.,
CHIEF OF BUREAU

C O N T E N T S

| SECTION | | PAGE |
|----------|---------------------------------------------------------------------------------|-------|
| 1 | SHIP AND SUBMARINE CONCEALMENT MEASURES | |
| | List of Measures | 6-8 |
| 2 | SURFACE SHIP CAMOUFLAGE AND CONCEALMENT | |
| | a. Remarks | 10 |
| | b. Concealment Measures for Surface Ships .. | 13-14 |
| | Written Descriptions | 13-14 |
| | Effectiveness and Suitability | 13-14 |
| | Illustrations | 15-16 |
| 3 | SUBMARINE CONCEALMENT | |
| | a. Remarks | 18 |
| | b. How to Use a Spray Gun to Get Special Submarine Concealment Effects | 20 |
| | c. Concealment Measures for Submarines | 28-81 |
| | Written Descriptions | 28-76 |
| | Effectiveness and Suitability | 28-77 |
| | Illustrations | 30-81 |
| 4 | SUBMARINE PAINTS AND PAINTING EQUIPMENT | |
| | Names | 84 |
| | Stock numbers | 85-86 |



LIST OF SURFACE SHIP AND SUBMARINE CONCEALMENT MEASURES

SECTION

1

SURFACE SHIP CONCEALMENT MEASURES

SURFACE SHIP MEASURES

| | PAGE |
|--------------------------------------------------------------------------------------------------------|-------|
| US 27 (Haze Gray)—All Ships, Boats, other Vessels and Craft (Exclusive of Submarines) . | 13 |
| (a) Word Description of Measure US 27 . . . | 13 |
| (b) Effectiveness and Suitability of Measure US 27 | 13 |
| US 17 (Ocean Gray)—All Ships, Boats, other Vessels and Craft (Exclusive of Submarines) . . | 14 |
| (a) Word Description of Measure US 17 . . . | 14 |
| (b) Effectiveness and Suitability of Measure US 17 | 14 |
| LC (Foliage Pattern)—Any Naval Surface Vessel | |
| (a) Word Description | 14 |
| (b) Effectiveness and Suitability | 14 |
| (c) Diagrams Showing Applications | 15-16 |

SUBMARINE CONCEALMENT MEASURES

SUBMARINE MEASURES

| | PAGE |
|--------------------------------------------------------------------------------------------------|-------|
| SS 17 G—Designed for Guppy Submarines with Details to Cover Anti-Submarine Submarines. | |
| (a) Word Description of Measure SS 17 G | 28 |
| (b) Effectiveness and Suitability of Measure SS 17 G | 28 |
| (c) Diagrammatic Illustrations with Detailed Painting Instructions for Measure SS 17 G | 30-34 |
| SS 11 G—Designed for Guppy Submarines | |
| (a) Word Description of Measure SS 11 G | 36 |
| (b) Effectiveness and Suitability of Measure SS 11 G | 37 |
| (c) Diagrammatic Illustrations with Detailed Painting Instructions for Measure SS 11 G | 38-41 |

SUBMARINE MEASURES

| | PAGE |
|--------------------------------------------------------------------------------------------------|-------|
| SS 7 G—Designed for Guppy Submarines | |
| (a) Word Description of Measure SS 7 G | 42 |
| (b) Effectiveness and Suitability of Measure SS 7 G | 43 |
| (c) Diagrammatic Illustrations with Detailed Painting Instructions for Measure SS 7 G | 44-47 |
| SS 27-O—Designed for Oiler Submarines Only | |
| (a) Word Description of Measure SS 27-O | 48 |
| (b) Effectiveness and Suitability of Measure SS 27-O | 49 |
| (c) Diagrammatic Illustrations with Detailed Painting Instructions for Measure SS 27-O | 50-53 |

SUBMARINE CONCEALMENT MEASURES

SUBMARINE MEASURES

| | PAGE |
|----------------------------------------------------------------------------------------------------------------------------------------------------------|-------|
| SS 27 F—Designed for Fleet Type Submarines (Shears Exposed) with Details for Cargo, Guided Missile, and Transport Submarines . . . | |
| (a) Word Description for Measure SS 27 F . . . | 54 |
| (b) Effectiveness and Suitability of Measure SS 27 F | 55 |
| (c) Diagrammatic Illustrations with Detailed Painting Instructions for Measure SS 27 F | 56–60 |
| SS 17 F—Designed for Fleet Type Submarines (Shears Exposed) with Details to Cover Radar Picket, Cargo, Guided Missile and Transport Submarines | |
| (a) Word Description of Measure SS 17 F . . . | 62 |
| (b) Effectiveness and Suitability of Measure SS 17 F | 63 |
| (c) Diagrammatic Illustrations with Detailed Painting Instructions for Measure SS 17 F | 64–68 |

SUBMARINE MEASURES

| | PAGE |
|--------------------------------------------------------------------------------------------------|-------|
| SS 11 F—Designed for Fleet Type Submarines (a New and Darker Measure) | |
| (a) Word Description of Measure SS 11 F . . . | 70 |
| (b) Effectiveness and Suitability of Measure SS 11 F | 71 |
| (c) Diagrammatic Illustrations with Detailed Painting Instructions for Measure SS 11 F | 72–75 |
| SS 7 F—Designed for Fleet Type Submarines (a New and Darker Measure) | |
| (a) Word Description of Measure SS 7 F . . . | 76 |
| (b) Effectiveness and Suitability of Measure SS 7 F | 77 |
| (c) Diagrammatic Illustrations with Detailed Painting Instructions for Measure SS 7 F | 78–81 |
| Presto S/M—Covered by Separate Instructions. | |



SURFACE SHIP CAMOUFLAGE AND CONCEALMENT

SECTION

2

Camouflage means to disguise
Conceal means to hide

Ship camouflage and ship concealment painting have gone through several stages of change and development. Various types described herein have been employed for different purposes and situations. In looking back over the entire experience, that of our own and of other nations, two systems stand out as having been repeatedly successful. Furthermore, these systems are so fundamental that it seems reasonable to believe they will continue to be the safest guides to the concealment policy of the future.

Before discussing concealment measures, a brief history of the false perspective patterns (camouflage) which were applied to most of our combat ships in 1944, and the reasons stated for discontinuing this type of ship camouflage is pertinent.

FALSE PERSPECTIVE PATTERNS (Course Deception System)

A type of ship camouflage, entirely separate and distinct from concealment painting, was developed by an American painter, Abbott Thayer, before the first World War and carried to a fine art by Everett Warner, one of America's foremost painters, during World War II. Although applied to a few ships of the U. S. Merchant Marine in 1918, it was little used by the U. S. Navy before 1943. The purpose of this system was not to conceal, but to deceive observers as to the course of the ship by painting a false perspective pattern on its sides and superstructure. It was believed that in many situations, particularly against enemy submarines, the advantage gained through falsification of the ship's course would more than offset any increase in the range to which it could be detected visually. The chief objections to deception painting are:

(a) Most of the course deception designs completely disregard, and lessen the possibility for, concealment.

(b) The false impression of a ship's course occurs only from visual observation and only at relatively short ranges after the true course has been well plotted from radar or sonar. Also, within short ranges a spread of torpedoes more than offsets any last minute false estimate of course. Hence, the objective of making the ships harder to hit was not achieved.

(c) The high contrasts in the "Dazzle Pattern" ships make them more conspicuous close aboard and hence attractive targets at close range. It was claimed that some of the ships hit had been singled out by Kamakazi bombers because of their conspicuity.

It is ironical that the majority of criticism from the Fleet which cited increased visibility as one of the chief objections to course deception painting, objected most frequently to the very feature—namely, the light shade of paint used—which probably reduced the ship's visibility as often as it increased it.

Also, in justice to the course deception system, it should be noted that the system in one form or another had a limited success as a ship type deception device. This argument was at one time advanced by some of the British advocates. However, the British adopted a policy (1946) which calls for reduction of visibility first, course and type deception second. Our present policy provides for taking full advantage of concealment painting to reduce the visual detection range and to lessen the probability of being detected at all. Since strong contrasts are necessary in the false perspective patterns to achieve course deception and since concealment depends to a large degree upon the reduction of contrasts, the false perspective pattern system is automatically eliminated.

NATURAL CONCEALMENT

One, and undoubtedly the best, system of concealment requires no instruction. It is to cover a ship with a cloak of local material, whether it be Arctic ice and snow, Mississippi mud, or Tulagi palms. All have been used, each successfully. No books were needed to instruct the Captain of one of our crippled ships to forge his way up a jungle inlet, anchor as close to the bank as possible, chop down trees, vines, and undergrowth and cover up. The ship was crippled and just ran to cover quite naturally. She didn't become entirely invisible, but her visibility was so reduced that the Japs who flew over the next day and for many days following didn't detect her beneath the man-made jungle that practically covered the guns, turrets, stacks, decks, and sides. That and the other examples of natural concealment were almost 100 percent effective. Similar examples include ships covered with ice and snow virtually lost to view in their Arctic surroundings; others covered by clouds of smoke that were obscured to aerial view. Countless numbers of small ground units have likewise been concealed. Individual gun emplacements, small groups of aircraft, and, in a few instances, small communities already partly hidden by their natural surroundings have been completely concealed by man-made additional screening with considerable care and cleverness. On the other hand much time, money, and effort have been wasted in trying, quite unsuccessfully, to conceal air stations, factories and large industrial areas whose geographical locations were well established and whose surroundings were such that they couldn't be missed.

Three lessons may be drawn. First, when trying to hide, it is natural to cover and blend as closely as possible with the surroundings. No special instruction for this is necessary. Second, partial concealment may be as good as entire obscura-

tion. Third, some things can't be hidden in broad daylight and it is just a waste of time to try. Although ships on the open sea can seldom be hidden at will, there are a lot of times when ships are hard to see anyway, and a little help by concealment painting makes the difference between their being picked up or not. This leads us to the second type of concealment, namely concealment painting.

CONCEALMENT PAINTING

The most effective example of concealment painting is that applied to small craft for night surface operations. Proper painting appreciably shortens the range to which these craft can be seen. The restricted light condition plus this concealment painting frequently provides complete concealment for carrying out night missions. For example, the special painting of U. S. submarines during World War II was so effective that they surfaced on clear starlit nights and approached on the surface to within 1,000 yards of the enemy without detection on several occasions. This added concealment was accomplished by carefully countershading and countershadowing away the pattern normally inherent in the submarine image. At the same time the painting was controlled so that the over-all tonal effect of the submarine under dim lighting matched closely the tones of sea and sky under the same light condition.

FOLIAGE PATTERNS

A second example of concealment painting which helped markedly was that applied to landing craft. Landing craft were painted with a mottling of greens and browns in such a way that their presence was not as readily detected against tropical foliage *and a number of other backgrounds, including harbors*. Nor were they as visible as far as those otherwise painted.

DARKER SHIPS

A third example was the darkening of the ships of the Pacific Fleet at a time when the Japanese had air superiority. Concealment or even partial concealment from overhead was then of prime importance. However, it should here be stated that the dark shade used (Navy Gray) was too dark.

LIGHTER SHIPS

A fourth successful example of concealment painting was the extremely light system, which by employing white and pale blue reduced the detectability of ships against the sky, both day and night, under most circumstances. In the last two examples the advantages gained were not without sacrifice; the dark Navy Gray paint made our ships hard for an aviator to see when he was looking steeply downward (45° or more) and had the sun behind him. But on the other hand, the fact that the shade used was extremely dark increased the visibility of these ships from practically all other points of view, both day and night; such as when looking more outward than downward against most sea backgrounds, and from every angle when viewed against the sky. The most efficient shade against aerial detection as a whole, is Ocean Gray, a shade about half-way between the prewar gray and Navy Gray. Ocean Gray is the basic shade for concealment measures US 17, SS 17 G, and SS 17 F. The 17 indicates the approximate reflectance in percentage, namely, that portion of the incident light which is reflected from the painted surface.

The white and pale blue designs of the "extremely light system", though least visible against the sky or calm seas, were most visible (to extremely long ranges) when viewed against a dark sky or a dark sea with the sun behind the observer. The

most efficient shade against ship and submarine detection as a whole is Haze Gray. Haze Gray is the basic shade for concealment measures US 27, SS 27 F, and SS 27-O.

CONCEALMENT MEASURES FOR SURFACE SHIPS

The wide variety of surface ship configurations coupled with all of the factors in nature which effect their optical detectability or their concealment requires either a very large staff of designers and the almost constant repainting of ships or necessitates a compromise on how the ships shall be painted. Obviously there is no alternative; a simplification of the problem is necessary. In order to arrive at a reasonable solution—one that will afford a worthwhile degree of effectiveness without being extremely bad under any condition—scores of experiments have been conducted over the past thirty years. The functions and tactics of ships have been studied. The optical properties of the natural environment in many different localities have been observed scientifically, theoretically and practically from many points of view.

As a result of these studies and observations, the foliage pattern and two old measures (old No. 13 and old No. 14) with minor refinements have been retained as the most effective and practical solution to the problem.

These three low visibility or concealment designs, with the latest refinements, are herein called measure LC, measure US 27, and measure US 17 (US 27 using Haze Gray and US 17 using Ocean Gray as basic shades respectively). These measures are recommended for all surface ships, both for peacetime and for combat operations. The shades of paint used in the two US measures were determined by Dr. E. O. Hulbert, Director of Research, Naval Research Laboratory, and have stood the test of more than 10 years of evaluation. The mottled pattern

measure LC, although originally designed for ships solely against backgrounds of tropical foliage has proved very effective against a wide variety of shore backgrounds.

Although not perfect under all conditions, these three measures are exceedingly helpful over a wide range of conditions. In many instances those searching have approached unbelievably close before being able to detect ships so painted.

There are those who sighting our ships under the most favorable conditions for sighting, may call the painting measures unsatisfactory; others who will feel that the painting is too simple to be most effective. Yet, after trying many colors, including black and white and all kinds of patterns, it has been clearly demonstrated that the simple measures LC, US 27 and US 17, are by far the best for surface ships, taking all conditions into consideration. Also, they happen to be simple of application and most easily maintained.

Concealment measures for submarines definitely are not simple of application and are consequently discussed in greater detail in Section 3.

In describing the effectiveness and suitability of various concealment measures, these remarks have been confined usually to generalities and to qualitative rather than quantitative values. The reason for this is that we still do not know enough of the answers in terms of feet, yards, or miles. To determine precisely how far a ship or a submarine can be seen, from all different directions under a wide variety of conditions, has been the object of a series of investigations for a number of years and is now more than two-thirds complete. Visual detection ranges are being determined by the Visibility & Concealment Branch of the Bureau of Ships for a number of types of objects including ships and submarines which are considered to be of the

greatest military importance. It is from the preliminary work on these problems that concealment ranges, depths, and relatively effective concealment values have been taken.

MEASURE US 27

(A) *Word Description.* (1) Apply No. 27 Haze Gray (5-H) (Stock No. G52-P-961) to all external surfaces of the ship above the boot-topping, except as noted in (2) and (3) below. On ships that have no boot-topping, apply to all surfaces above the upper limit of the bottom paint except as noted in (2) and (3) below.

(2) Apply smooth Dark Gray Deck type A (Stock No. G52-P-1406-50) or non-skid Dark Gray Deck type B (Stock No. G52-P-1408-50) to steel decks and all other horizontal steel surfaces exposed to aerial observation.

(3) Apply Glossy White (Stock No. G52-P-5305) or Base White (Stock No. G52-P-5335) to all overheads and to the undersides of all other external horizontal surfaces.

(B) *Effectiveness and Suitability.* This measure has very low visibility at night and at twilight. It has low visibility to submarine and surface observers in hazy, cloudy, or foggy weather especially when accompanied with periods of weak sunlight. It has high visibility in bright weather when seen against the water from steep downward angles. This measure has moderate visibility and is sometimes very hard to see against the water near the horizon, i. e., low grazing angles, even in bright sunny weather. It is useful in submarine infested areas, where ships are exposed entirely against a sky background to submarines and low flying distant aerial observers. This measure is more effective than measure US 17 in this regard, but less effective than measure US 17 as a purely antiaviation measure.

MEASURE US 17

(A) *Word Description.* (1) Apply No. 17 Ocean Gray (5-0) (Stock No. G52-P-965), to all external surfaces of the ship above the boot-topping except as noted in (2) and (3) below. On ships that have no boot-topping, apply to all surfaces above the upper limit of the bottom paint except as noted in (2) and (3) below.

(2) Apply Smooth Dark Gray Deck type A (Stock No. G52-P-1406-50) or Nonskid Dark Gray Deck type B (Stock No. G52-P-1408-50) to steel decks and all other horizontal steel surfaces exposed to aerial observation.

(3) Apply Glossy White (Stock No. G52-P-5305) or Base White (Stock No. G52-P-5335) to all overheads and to the undersides of all other external horizontal surfaces.

(B) *Effectiveness and Suitability.* This measure has low visibility to aerial observers looking steeply downward, and to surface observers looking away from the sun in bright sunny weather. It has high visibility in bright weather to aerial observers at distant ranges looking more toward the sun than away from it. Its maximum utility is against steep aerial observation, and against backgrounds of sea and land over a wide range of conditions. In this regard it is more effective than measure US 27, but as an antisubmarine measure, is inferior to measure US 27.

NOTE. - At sea US 27 or US 17 are more suitable than measure LC even for Landing Craft. Conversely, the LC pattern is applicable to *all* ships and craft against land backgrounds.

MEASURE LC

(A) *Word Description.* This measure consists of applying a designed pattern of greens, browns, and black to the exteriors of landing ships, and to other ships and craft. This pattern

should be spray painted in order to avoid hard or sharp edges between colors. The scale of the pattern shown in figure 1 does not change regardless of the size of the vessel to which it is applied, so that on an LST it looks as shown in figure 2 and on an LCI looks as shown in figure 3, PT boats as in figure 4, and on an ARB as in figure 5.

(B) *Effectiveness and Suitability.* This pattern is appropriate for helping to hide ships and smaller craft in rivers, harbors, etc., especially near shore. Although originally designed for ships against backgrounds of tropical foliage, it proved to be surprisingly effective against a wide variety of backgrounds. For example, an LST, when viewed from the Submarine Base at Pearl Harbor across the water about a thousand yards away, blended so well with its surroundings that the ship as such had to be pointed out and was not noticed at all by a casual observer. As indicated in "Remarks on Camouflage and Concealment," page 11, this painted foliage pattern is not as effective as real natural cover, but it does have merit in itself. Also, it provides a good foundation on which natural foliage can be most realistically constructed.

Stock numbers for mottled foliage pattern (measure LC) paints are as follows: (See figures Nos. 1, 2, 3, 4, and 5.)

| LC paints | Specifica- tion Nos. | Approxi- mate reflectance | Navy Stock No. |
|----------------------------|-------------------------|---------------------------------|----------------|
| Haze Green..... | 52 P 55 | 30 | |
| Ocean Green..... | 52 P 56 | 20 | G52 P 5217 60 |
| Navy Green..... | 52 P 57 | 10 | G52 P 5213 60 |
| Green Tinting (5 GTM)..... | 52 P 50 | 2 | G52 P 843 110 |
| Ocean Brown..... | 52 P 80 | 20 | G52 P 5214 60 |
| Dull Black No. 104..... | ----- | 2 | G52 P 5075 |



Figure 1.

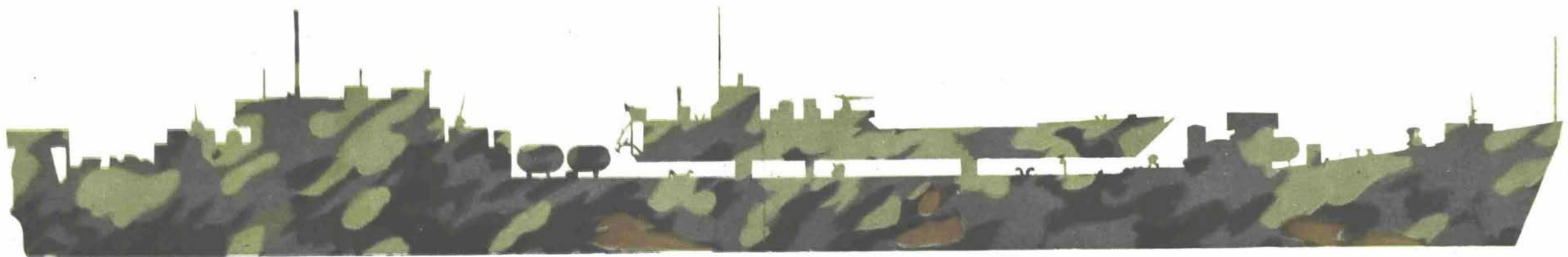

Figure 2.

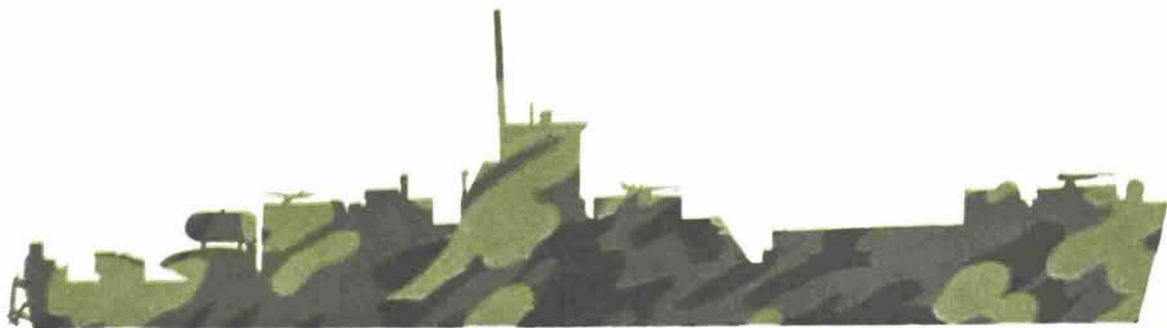

Figure 3.



Figure 4.



Figure 5.



SUBMARINE CONCEALMENT

SECTION 3

There are many reasons for having a relatively large number of submarine measures. By their very nature, submarines are designed to take full advantage of concealment, preceding and subsequent to their surprise attacks. In spite of sonar and radar, submarines need all the concealment against visual detection that can be provided and good concealment painting does play an important part. Concealment designs are based on the *configurations of the submarine* and on the *environment in which they are to be concealed*. Hence, each different type requires a different design and modifications of these are made to meet various *tactical situations* which determine the various environments in which they will operate and the different points of view under which they may be exposed.

Designs are all slanted primarily for concealment submerged. But because of the effectiveness of the night surface attacks made by Fleet-type submarines during World War II, the measure especially designed for these tactics will be available as long as we still have Fleet-type submarines. In the event of another large scale war in the near future, the same tactics used in World War II might well be reemployed. The measure described in NavShips 250-631 as 32/3SS-B (known as the "light gray job") will hereafter be designated SS 27 F. Likewise, the other measure which proved very successful during the second World War, namely, the one known as the "dark gray job," and described in NavShips 250-631 as 32/9SS, will also be retained on the list of measures available to the submarine forces for the Fleet-type boats.

The latter is now SS 17 F. These old measures have been slightly modified by the employment of better deck paints. The number 27 in SS 27 F (old 32/3SS-B) refers to a 27 percent reflectance paint. The reflectance is one of the requirements in

the specifications for Haze Gray, the basic shade used in measure SS 27 F. The number 17 in SS 17 refers to 17 percent reflectance paint, namely Ocean Gray. The "F" in the new numbering designates that the primary use of this measure is for Fleet-type submarines, "G" for Guppy, and "O" for Oiler. Two other measures are presented here for Fleet-type submarines. Their basic shades are a little darker than the Ocean Gray, the new shades being Outside Gray No. 11 and Navy Gray No. 7. Also, there are details for Radar Picket, Guided Missile, Cargo, and Transport Submarines. Also, there are details for Anti-Submarine Submarines and a measure for Oiler Submarines. As new type boats are built measures will be hand-tailored to fit them.

BASIC PRINCIPLES

In painting submarines it is necessary for the painters themselves, as well as the First Lieutenant or Chief Petty Officer who supervises the job, to have some idea of the theory underlying concealment painting. The manner of painting is similar for all the measures, but the measures themselves differ in two respects. First, the designs are made to fit each individual class and type of boat, and secondly, some measures are lighter or darker than others. When the basic shade of a measure has been established, the rest of the design falls into place.

The object of all submarine concealment designs is to make the boat appear like a soft gray cloud of one tone, namely, the same tone as the background against which it is expected to operate most of the time or at the most critical times. It is therefore necessary to use a more reflectant paint on the surfaces which get less light and use a less reflectant paint on the surfaces which get more natural light. There are two principal reasons

why surfaces get more or less light. One is the slope of the surface and the other is the extent to which the surface is covered or crowded and overshadowed by other surfaces. *The relative shade on each* fully exposed surface is governed to a large degree by its slope; that is, the degree to which the surface slopes away from the vertical, which has the basic shade. If a fully exposed surface is perfectly straight up and down (vertical) that surface gets the basic shade. When the surface changes away from the vertical and faces upward it gets a darker shade than the basic and the degree to which it is darker is determined by the slope, so that on a flat horizontal surface or one that is practically horizontal like the main deck, and faces *upward*, a paint approximately black is used. A horizontal surface that faces *downward* is painted white. In the past, black has been used for decks, but it has been found that both the black striping and the anchor chain black are too dark. The new deck paint is being very carefully manufactured to get just the right shade. It is almost black but not quite. It is still glossy. This new "Deck Paint Mixture" on a horizontal surface is almost impossible to see 5 feet beneath the surface of deep sea water. *This shade should not be used on any surface that slopes more than ten degrees from the horizontal.* A fully exposed surface that is halfway between vertical and horizontal should be as near as possible to halfway between the basic shade for the vertical side and the shade for the horizontal surface.

COVERED AND CROWDED AREAS

There are a number of platforms and braces in between the shears and other parts of the Fleet-type boats, and even in the guppies inside the bridge, which face directly downward. The direct rays of the sun can never strike these and therefore they are naturally very dark. These surfaces and the bottom sides of platforms and overheads should be painted white as a counter-

shade. The most effective paint to use for a countershade is white and there are a number of places, especially on the Fleet-type boats, where countershading must be done. However, white paint should never be exposed to the aviator. It should never be exposed to the direct rays of the sun.

Other areas, especially on the Fleet-type boats, are covered or crowded and get very little light. Such areas are found around the shears of Fleet-type boats, and up inside the sail of the guppies and inside of port and limber holes. There are other places inside the bridge and in between the bulkhead and the shears, which may be exposed to the direct rays of the sun but seldom are, and are generally too dark. These surfaces can't be painted white, but do have lighter shades of paint than their slopes alone would indicate.

In going from naturally light areas to naturally darker areas, whether because of the change in the slope of a surface or because of changing from a crowded area to one more exposed, it is necessary to follow closely the instructions on the techniques for making gradations. These changes from light to dark must be made as gradual and as smooth as possible.

It is said in baseball, "It takes only one to hit it." We might say in submarine warfare that "It *may* take only one sighting of a poorly painted submarine to sink it." The difference between a well painted boat and a poorly painted boat may not make any difference to life or limb 99 cases out of 100, but that 1 case could be the time when someone was close enough to do damage. A perfectly painted boat cannot be seen under any light or sea condition below 120 feet keel depth. A poorly painted boat can be seen under some conditions to keel depths below 200 feet. These facts should convince any member of a submarine crew who wields a spray gun that he must try to do a good job. By doing a good job he is surely contributing to his own safety as well as to that of the others on the boat.

All submarine concealment measures require special painting techniques for various parts of the boats. Since submarines need more concealment than any other type of ship and consequently more careful painting, regular straightforward painting of uniform, solid coats is not sufficient.

The streamlined surfaces of submarines are more subtle than the big flat surfaces of large surface ships and require, therefore, the subtle blending or grading of different shades of paints. This blending from dark shades to lighter shades will resemble the smooth shading of fish and is absolutely necessary to provide maximum concealment for submarines.

The fact that the larger forms of submarines are not quite as simple as those of fish and have not the same movement of fins, tail, etc., requires introducing certain modifications in the painting design to compensate for these differences. In order to achieve the greatest concealment possible, a number of shades of paint ranging from black to white are necessary for submarine painting. In section 4 of this booklet there are descriptions of paints for all submarine concealment measures and the stock numbers to be used in ordering the paints. Painting equipment is also listed in section 4 and the stock numbers given; also, there are a few remarks on the upkeep of equipment which may prove helpful to the painters.

The suggestions for handling the spray gun which follow are the result of a great deal of experience and are given to assist the painters in doing a good job rather than being arbitrary orders to do something in a way that we want it done. If the painters will follow these suggestions, they will make the boats harder to detect and, to borrow a phrase, "this life they save may be their own."

PREPARATION

In appendix 6, "Painting Instructions," and "Damage Controlman 3 and 2," NavPers No. 10571, will be found a number of good suggestions for the preparation of surfaces which will not be repeated here. All painters should study appendix 6 and the D. C. Manual. There are copies on every ship and at every yard in the Navy. Also there are two good instructive movies: MC-4196 on "Use and Care of Paint Spray Equipment," and MN-6788A on "Topside Painting and Surface Preparation." There are four precautions to be taken before painting is begun that are musts: (1) Surface *must* be clean, (2) paint *must* be the right consistency, (3) paint *must* be well stirred and strained, and (4) spray gun *must* be clean.

Paint shall not be applied over dirt or oil. Paint applied on top of oil or dirt will not stick the way paint will stick to a perfectly dry, clean surface. Sometimes it won't last overnight. *Paint shall not under any circumstances be diluted with too much thinner or turpentine.* If this is done the paint loses its body and loses its binding qualities so that it will not stick well against the deck or sides of the boat. In practice there has been a tendency to reduce paint with thinner, turpentine, and the like, out of all proportion. Actually, the paints that come from the paint factories at Norfolk and Mare Island, where most of our paints are manufactured, are of a consistency that will go through a clean, repeat clean, spray gun at the proper air pressure and temperature. The proper air pressure, incidentally, for the average spray gun is from 50 to 65 pounds.

Generally, the paints can use a little thinner. In cold weather more thinner is required, but under no circumstances should

more than one part of thinner to ten parts of paint be used. If paint is properly strained and stirred, or mixed with a shaker, which is better yet (and use of shaker wherever possible is urged), paint will have a consistency that can go through a clean spray gun very easily without thinning it down to the consistency of water. Not only will paint that is thinned too much peel off quickly, but it will also fade and lose its effectiveness for concealment.

SOLID COATS FIRST

All of the bare metal on the boat must be covered with two coats of primer and one solid coat of paint for protection before any spattering gradations are applied. Time and trouble can

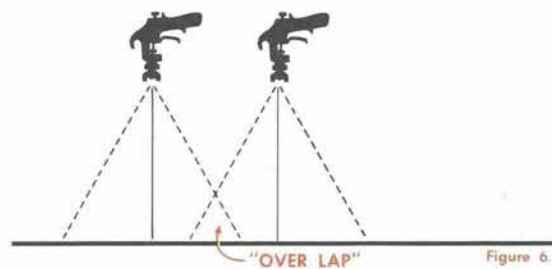

Figure 6.

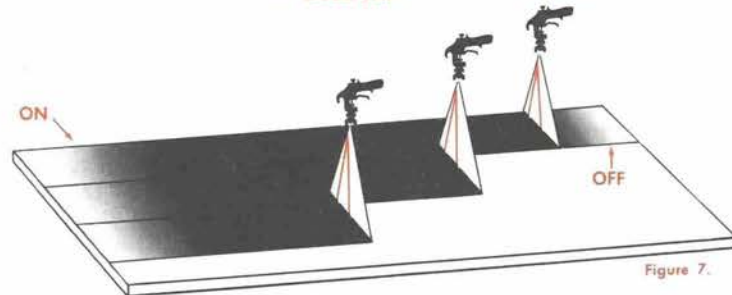

Figure 7.

be saved by laying all solid coats along the length of the ship in parallel lines slightly overlapping one another (figs. 6 and 7) rather than on a hit or miss random stroking. Before starting to paint note the direction in which a wind may be blowing.

This goes for solid coats to some extent, but it is especially important when graded spattering is done as later described. If the wind is blowing from the bow, it is better to start painting from the bow rather than from the stern. By this is meant that the whole job should start from the bow and also that each stroke of the spray gun should start from the bow and go aft (fig. 8). While painting solid coats, the spray gun should be

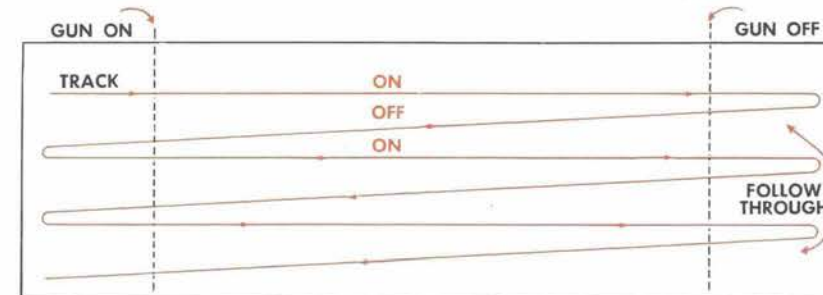

Figure 8.



Figure 9.

aimed directly at the surface of the boat (fig. 9). The gun should be held about 10 inches from the surface throughout the stroke. "Start it at 10 inches and keep it at 10 inches" (fig. 10). Don't swing the gun in an arc (fig. 11). Swinging will take the

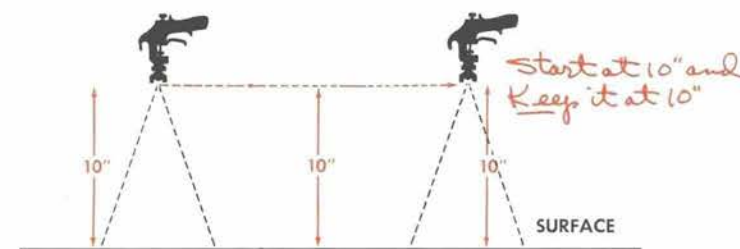
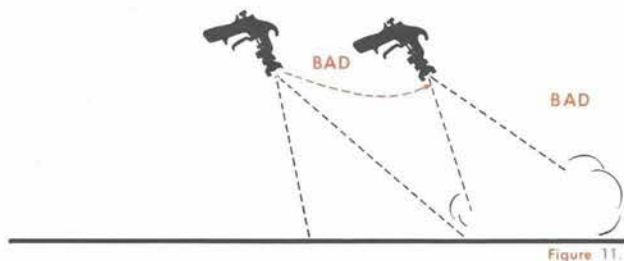

Figure 10.



gun at the beginning and the end of the strokes too far away from the surface. In the center of the swing the gun will be too close. Shooting at an angle is also *bad* (fig. 11). The right way will help to avoid unevenness, puddles, and thin spots.

HOW TO GRADE A SURFACE

All submarine paint designs require a number of gradations. To make a smooth gradation from one shade of paint to another requires one of three methods. One method is to paint a series of thin parallel bands, each of a different shade of paint. These shades would be painted in sequence from the lightest to the darkest or vice versa. This method is not the most practical nor the simplest since it requires more shades of paint and a good deal more time to apply than is ordinarily available. There are two other methods: the "STEP TECHNIQUE" and the "DRAGAWAY TECHNIQUE." Each method, with a little practice, can be very fast and effective. Each method requires some practice and skill in handling the spray gun. Both methods are known as "fogging" or "fading off" with spatter. A solid coat, generally the lightest gray, is first applied. A spattering of a darker shade is then sprayed in successive diminishing amounts over the solid coat. "Diminishing amounts" means that fewer and fewer of the tiny specks of paint which go to make up the entire spray actually reach the surface being painted.

The STEP TECHNIQUE method is used when the wind is blowing *across* the line of gradation. The spattering is done by

tracking the gun a given distance on the first stroke and then farther away on each succeeding stroke. (See fig. 12 on which is written STEP TECHNIQUE.)

When the wind is blowing *along* the line of gradation, use the DRAGAWAY STROKE TECHNIQUE (fig. 13). A further refinement in the DRAGAWAY STROKE TECHNIQUE is the manner of releasing the trigger of the spray gun. The trigger should be released before the end of each stroke.

Before starting a spattered gradation, check up on the direction of the wind and be sure the undercoat is right (fig. 14). When painting is done as in figure 14, which is proper, the wind

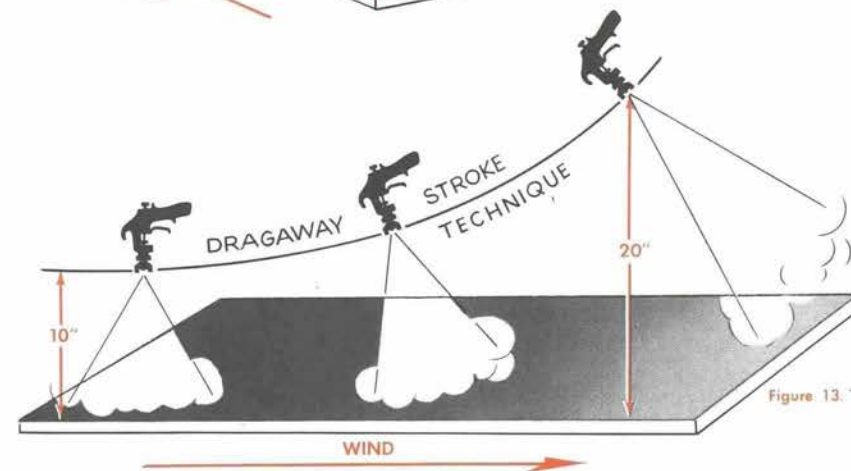
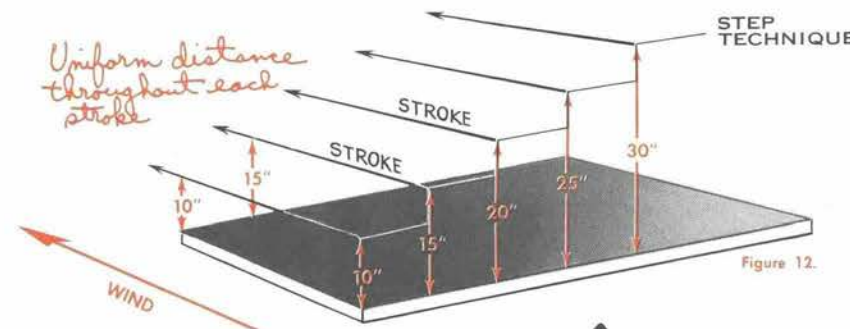

will help you because it will blow a foglike spatter of paint where it fades out. But if fogging against the wind is attempted or the

wrong undercoat is left unchanged the wind will blow the paint the wrong way under such circumstances. It will be impossible to get a smooth gradation, and besides more paint will be sprayed in the faces of the painters than on the ship.

What has been said so far is fundamental. *Controlled spray technique for good smooth grading is one of the most important requirements for all submarine concealment measures.*

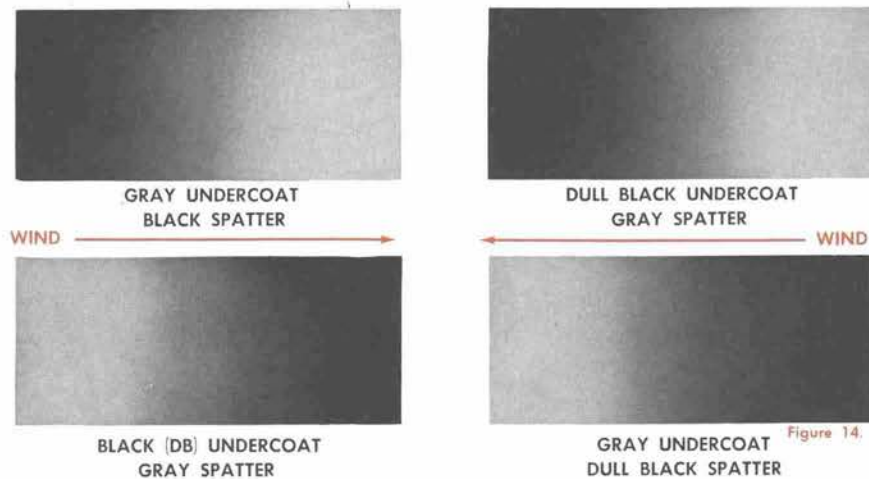

A very important spatter area on all submarines is that required from the main deck to the sides of the boat. In the old measure 32/3SSB a 2-foot margin was made using dull black No. 104 all around the outer rim of the flat portion of the main deck. This two-foot border has now been eliminated. Dull black will still be used to shade from the outer edge of the main deck to gray on the side. Assume that the side is already painted with No. 27 in a solid coat which extends not only on the vertical side but also on the round "tumblehome" or shoulder toward the flat portion of the main deck (fig. 15). Assume also that the wind is either from the bow or stern, in which case the STEP TECHNIQUE is used. The first stroke then should be

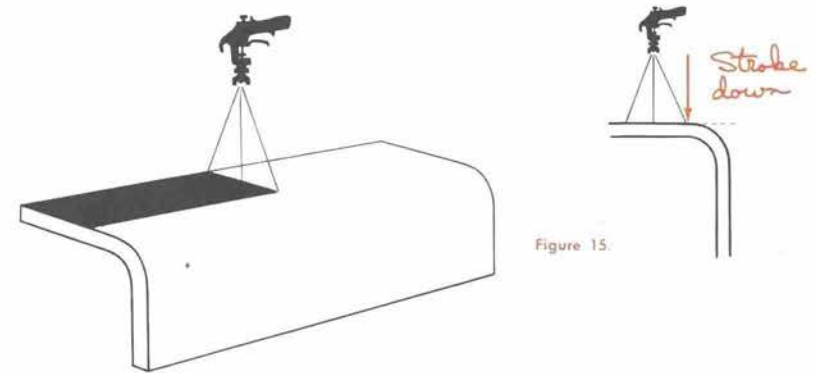

with the gun close to the edge of the last flat portion of the main deck and pointed directly downward. The stroke will be from bow to stern or from stern to bow, depending on the direction of the wind (fig. 15). The next stroke should be made with the gun not quite so close to the boat so that the spatter is not quite a solid coat; but the gun should be aimed directly at the surface just the same (fig. 16); the direction of the stroke should again be parallel to the first, from bow to stern or vice versa. For each succeeding stroke the gun is held a little farther from the boat, but in each case aimed directly at the surface to be painted (fig. 17). Throughout the *entire period of each stroke* the distance from the boat is not varied. Thus, for the entire length of one stroke the spatter is even. By the time the

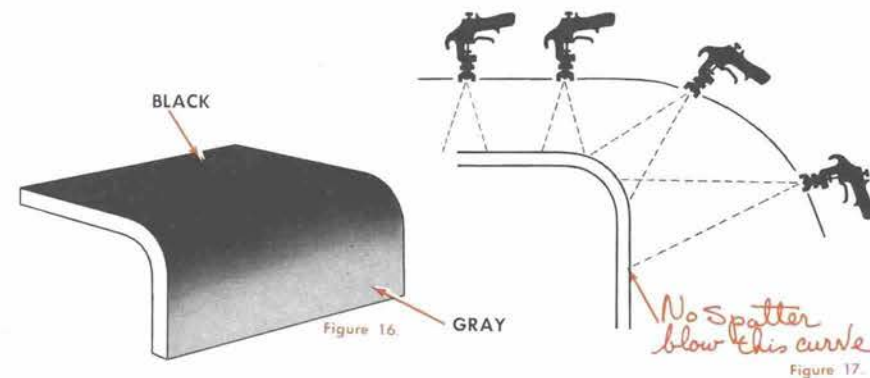

place is reached where the gun is pointing in a horizontal line (that is, at the point where the curved portion of the shoulder joins the straight up and down side), no spatter should be reaching the boat. The spatter should stop a little before the gun is shooting directly outward because when shooting directly outward a certain amount of spray will go below the point of aim.

When the wind is blowing, not from the bow or stern, but across the boat, this shoulder is better painted with the Drag-Away Stroke Technique as described in figure 13.

When the wind is blowing upward, gray must be used for the spatter (fig. 18). When the wind is blowing downward black must be used for the spatter (fig. 19). When there is a down

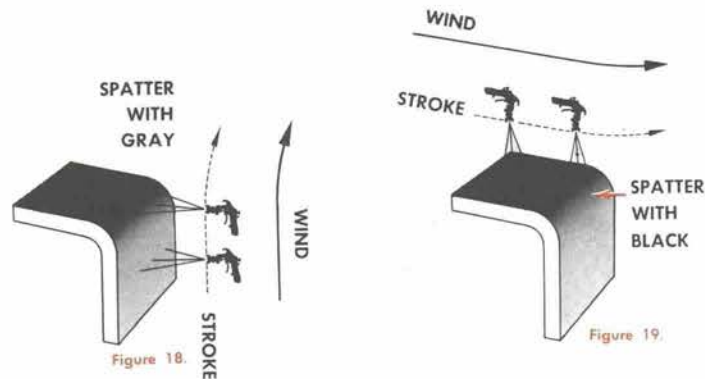

draft near the bow there is a serious danger of getting the spatter too low (fig. 20); that is, below a vertical surface, for here the rounded shoulder does not stop at the vertical side but cuts back under. This shoulder can't be properly graded from the deck without an extension arm for the gun. All submarine tenders are getting extenders. However, if no extenders are available, work must be from the pier or from a platform rigged on a punt or raft. Painters must get up high to get the spray gun close to the boat and aim it in the right direction. This rounded

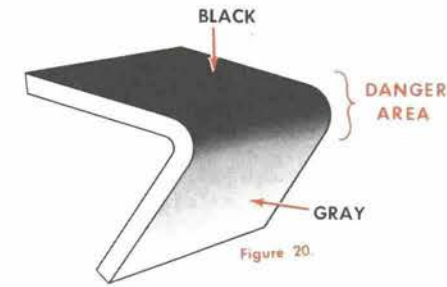

shoulder is a most revealing part on a submarine. When it is not properly painted it can reveal the presence of the boat either on the surface, at periscope or snorkel depth or below when no other part of the submarine can be sighted. This is recognized as one of the most difficult parts to paint, and a smooth job is impossible unless the technique is understood and the effort is made to accomplish it. But time and effort here pay off.

As far as techniques are concerned, there is another place that should be called to the attention of the painters—the necks of periscopes and their streamlined fairings and radar masts. These are very important areas. The necks (the uppermost 5 feet, approximately) of the periscope have received the most unorthodox paint jobs imaginable in the past. It was found that a periscope that had been properly painted was much, much harder to see and often unseen by aviators close aboard. One badly painted scope could be seen more than *10 times as far* as a well painted one, on an average of several observations. There is only one right way to paint these, and the streamlined envelopes that are being installed as fairing around the periscopes of the newer boats. This painting design was arrived at after many tests and must be carefully followed. The way to paint a periscope or its fairing is to cover it solidly with Haze Gray. Then dark spots of Navy Gray are added, irregularly placed with plenty of space between them. About a third of

the periscope neck or fairing should be covered with dark spots and two-thirds of the Haze Gray left exposed. These spots should be about the size, roughly, of the palm of one's hand, never less than three inches and not more than eight inches in any one dimension. The spots should be solid in the core and fogged out toward the sides. Each spot can generally be made with one shot of the gun by squeezing the trigger and releasing it quickly. The gun should be about 10 to 14 inches away from the scope depending on the pressure in the gun. When spots are made too big and placed too close together they will merge in a short distance into a solid dark gray. If the spots are not big enough or placed too far apart, the periscope will look solid gray at a short distance—too light. The idea is to break up the periscope neck so that it will look spotty. This has the best chance of concealment among the light and dark areas of the waves. There is no chance to change the shade of the periscope neck for every condition of sea, but this broken pattern has been found to be the best way to paint a periscope neck and the streamlined fairing for all conditions.

Since two of the old measures are being retained, the so-called light gray and dark gray jobs of World War II, which are now designated as SS 27 F and SS 17 F respectively, attention is called to one thing that has become an all too common fault, namely, the quick change from the gray on the side to the black

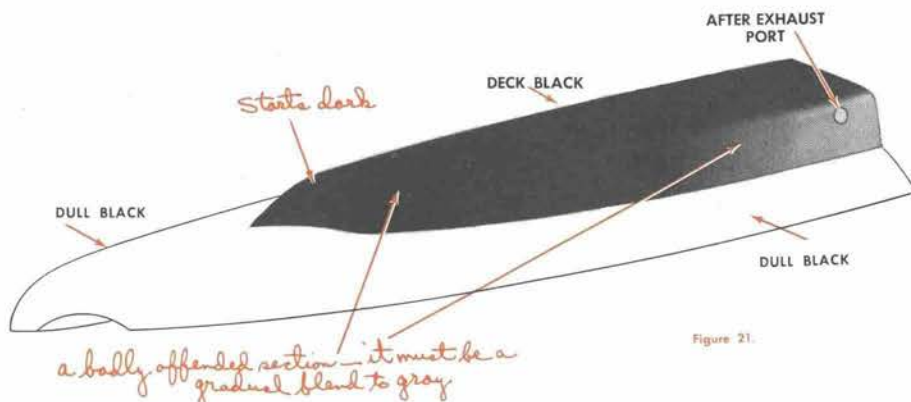

Figure 21.

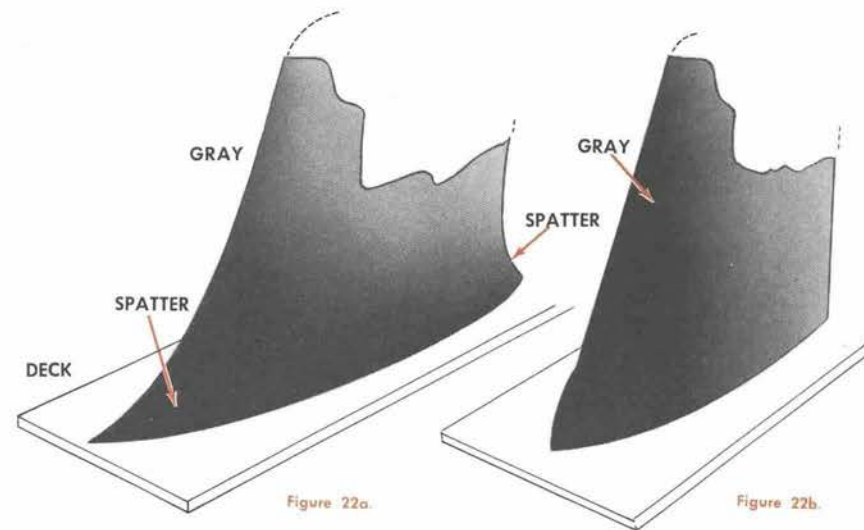
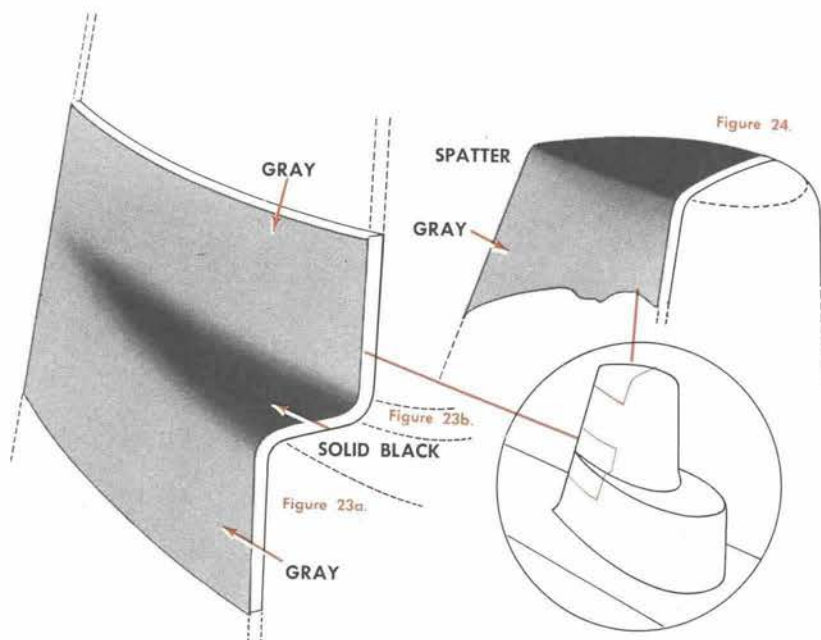

Figure 22a.

Figure 22b.

at the stern. In many cases a sharp, hard, diagonal line was made to go from main deck downward and slightly aft to the pressure hull. Instead of a hard, sharp line, there should be a gradual gradation. On the light measure SS 27 F, the gradation from the gray to the black should be accomplished over a long distance, namely, the entire distance from the after exhaust port becoming solid black when it gets almost to the end of the flat side (fig. 21). On the darker measures the gradation can start a little farther aft but there should always be a gradual change. See illustrations on this.

Another difficult but very important part to grade off is the curved surface of the sail of a guppy which starts at the main deck and goes up (fig. 22). In most of the guppy boats this is a sharp little curve at the most forward portion (fig. 22a), and a more gradual curve where the after portion joins the main deck. It is difficult to describe precisely how much of a spatter should be used or how far up it should be carried because it varies around the base of the sail. The lowest part can be painted almost solid dull black and the spatter carried up and



very gradually tapered off until about 2 feet above the main deck near the forward portion of the fairwater (fig. 22a). But the upper portion of this 2 feet should contain very little spatter. The fade-off must be gradual. The after portion (fig. 22a) of the fairwater has a rounded area that faces upward and outward all the way up to the bridge opening level, so here it is necessary to carry a small amount of spatter all the way up along the "spine" to the bridge opening level.

There is also a very important section where the flat portion of the bridge opening level curves outward and downward to join the side of the bridge (fig. 23a); also where this level curves inward and upward to join the higher portion of the sail (fig. 23b). Another place which must be carefully handled with a graded spatter on the rim is the topmost part of the sail (fig. 24). Note that this topmost part will be nearest to the surface of the sea when the boat is submerged. There are

occasionally times when boats are at shallow keel depths and wish to more or less stand by, possibly after an approach to a position or in lying off some coast. In such a case the areas of the boat nearest the surface may easily be seen if not properly painted.

The more a surface slopes upward, the darker it should be and if it is a graded surface the darkest portion of the spatter should face more nearly upward.

Note again that in some cases it will be necessary to change the shade of the basic undercoating in order to apply a spatter other than black. For example, if black spatter has been carried too far or if it is too solid, because of wind interference or for some other reason, it will be necessary to go back over the area with a gray spatter in the inverse order to correct it, or to paint the whole under surface black and then go back over it with a gray spatter (fig. 14). This will require the changing of the shade of paint in the spray gun. For this and other reasons, such as the difficulties of getting good pressure pots and keeping them in good order, and the bother of lugging these heavy pressure pots around the boat, it has been found much easier to use the small quart cup guns. It is also easier to clean a cup gun and change the shade of paint in the gun than to change the paint in a pressure pot. Theoretically, pressure pots save time but this seldom works out in the actual painting of submarines. After the paint in a quart cup is used up, to refill it takes very little time. Professional painters generally prefer these quart cup guns to heavy pressure pots. This applies especially to submarine painting. The use of pressure pots is fine for large ships where change of the shade of paint is seldom necessary and where tremendously large surfaces are covered.

If paint has not been strained, it will clog up the gun and

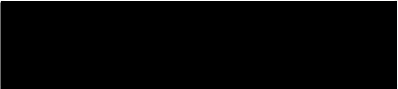

make it spit irregularly. This makes a good grade impossible. If the gun spits or becomes clogged, it will be necessary to stop and clean it and to restrain the paint; there is no other answer. There is nothing more annoying than to have a tool that doesn't work well, and that goes for painting "tools" as well as any others. Keep paint spray guns clean and in good working condition and learn how to use them. Then painting can be fun instead of a "pain in the neck." The finest graded washes in

all commercial art work are done with a type of air spray equipment called air brushes. Your spray guns are built on the same principles exactly—they are just bigger for a man-sized job. Learn to control the air and the distance from the surface. When the gun is clean and air pressure is right, little or no thinning is necessary. This will give a more lasting paint job, two-to-one, over paint which has been diluted too much with thinner.

MEASURE SS 17 G WITH DETAILS TO COVER ANTI-SUBMARINE SUBMARINES

NOTE.—"How to Use a Spray Gun to Get Special Submarine Concealment Effects," pages 20 to 27, shall be required reading for all painters before starting to paint this measure.

(A) Word Description. Ocean Gray (5-O) Stock No. G52-P-965, is the basic shade for this measure and shall be applied to the vertical sides from the pressure hull to the topmost part of the boat except as hereafter noted and shown on the illustrations for this measure.

Haze Gray (5-H) Stock No. G52-P-961, shall be applied to all of the vertical or nearly vertical surfaces that are inside the bridge structure and to all surfaces 6 inches or more inside limber holes that can be reached by a painter stationed near the water line outside the boat, and to the top of the hull that is covered by the superstructure.

Haze Gray (5-H) shall also be used inside the bridge where white or deck black do not apply and inside the fairwater "sail" from the top of the sail downward for 3 feet. (Below this level white is used.)

Haze Gray (5-H) shall also be applied in solid coat to periscope necks and streamlined periscope fairings as the background shade for the dark spotting.

Navy Gray (5-N) Stock No. G52-P-963, shall be used for the dark spots on periscope necks and fairings. How to paint the periscopes is described on page 24 and also illustrated.

Deck Paint Mixture shall be applied to all decks except on the rounded edges where Dull Black No. 104 is used as later described and illustrated.

Dull Black No. 104 shall be applied to all *rounded* surfaces facing generally upward including the rounded edges of decks, the upturned rounded surfaces of radar, the rounded top of sonar domes, top of snorkel, all hand rails, the top of the pres-

sure hulls, and tanks between the low water line and superstructure.

Dull Black No. 104 may also be used for making the spatter gradations from dull black areas to lighter areas as illustrated for this measure.

White No. 6, Stock No. G52-P-5305, shall be applied in solid coat to the overhead and to all other areas of the bridge except those portions which may become exposed to the direct rays of the sun.

White No. 6 shall also be applied in solid coat to the shears, braces, sides, and all other stationary surfaces inside the sail up to three feet from the top of the sail. This excludes radar antennae, snorkel, and periscopes.

White No. 6 shall also be applied to the interior of the superstructure above the hull and below the main deck (forward of the conning tower), including the under side of the main deck and the interior of the sides. Aft of the conning tower, inside the superstructure, is unimportant. White shall *not* be applied to the top of the hull, even beneath the main deck.

Snorkel exhaust baffle plates: The *top* of these plates, that is the horizontal surface which faces upward, shall be painted by *brush* with Dull Black No. 104, Stock No. G52-P-5075. The *under* side of these plates shall be painted by *brush* with pure white, Stock No. G52-P-5305.

(B) Effectiveness and Suitability. After observations of more than 2 years in comparison with boats painted lighter and painted darker, this measure has proved to be very effective both for submerged operations and for daytime surfaced operations, with emphasis on submerged. All submarines are hard to pick up initially when submerged unless they have been carelessly painted with light areas upwardly exposed. A boat painted

with this measure is hard to follow even when one sees it submerge, and the harder still to pick up again when contact has once been lost, even though the boat remains at a keel depth of 80 feet during good light, sea, and weather conditions. However, under the most favorable sighting condition, glassy smooth sea, sun between 50° and 75° altitude and behind the observer, these boats have been followed down to depths around 120 feet. They are almost never detected originally by visual sightings submerged and the chance of so doing is about one in fifty. This paint measure is not as apt to be sighted on the surface as darker boats, but on the other hand can be seen a little more easily and a little deeper, under favorable sighting conditions, than a boat painted darker as in measures SS 11 G or SS 7 G. When sighted on the surface it appears too dark about as often as it appears too light. Below the surface, more often it is too light. Since most of the contacts still appear to be made on surfaced submarines, it is felt that this measure offers the greatest all-around advantage for guppy and snorkel submarines that spend any time at all on the surface. However, the selection of this or of one of the two darker measures hereinafter described is entirely up to the discretion of the Chief of Naval Operations, Fleet and Force Commanders. Attention is here invited to the fact that there are no differences in the manner of painting horizontal upturned surfaces. The differences are very slight for intermediate slopes and markedly different only on the surfaces that are vertical or approximately so.

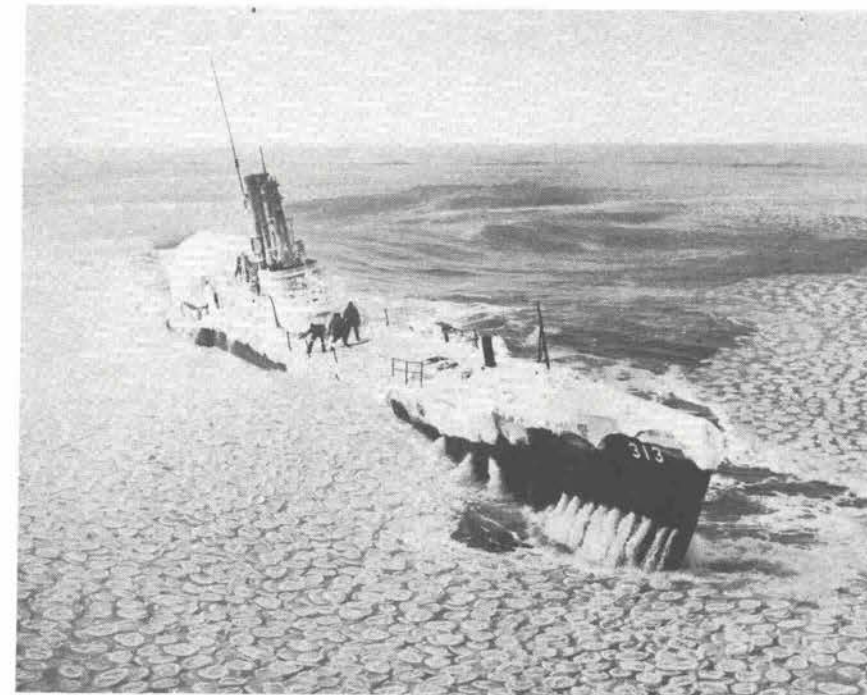

MEASURE SS 17 G

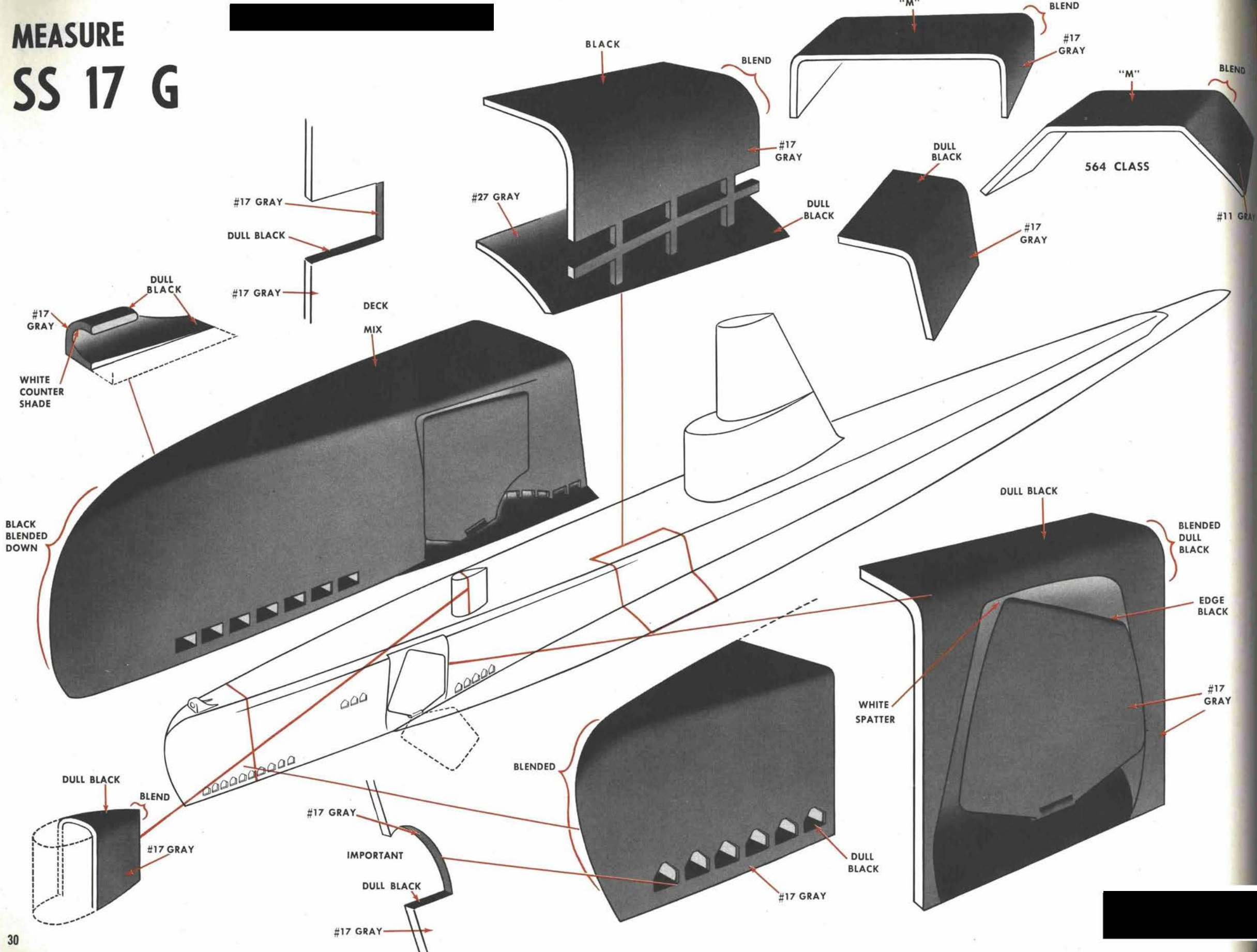

MEASURE SS 17 G

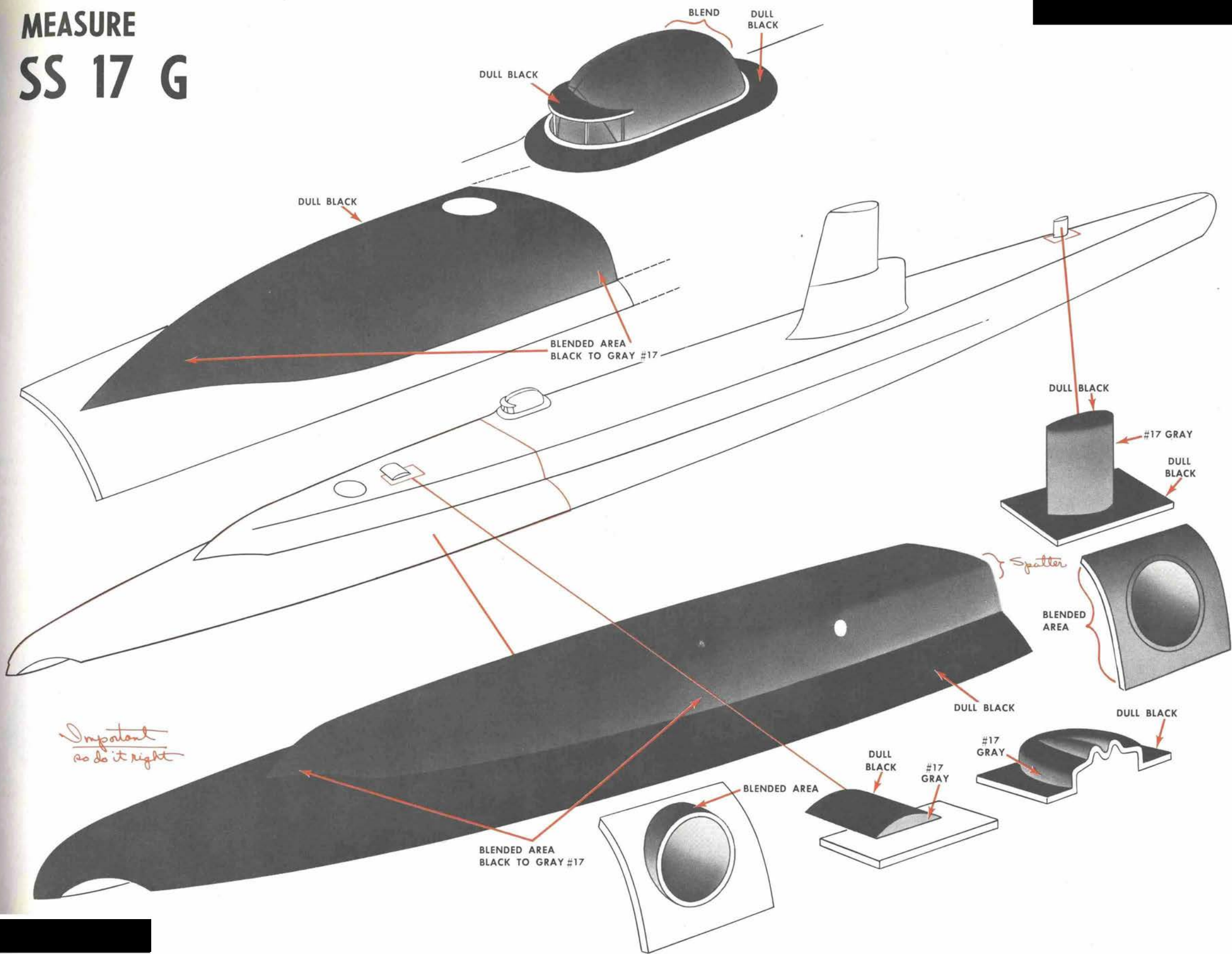

MEASURE

SS 17 G

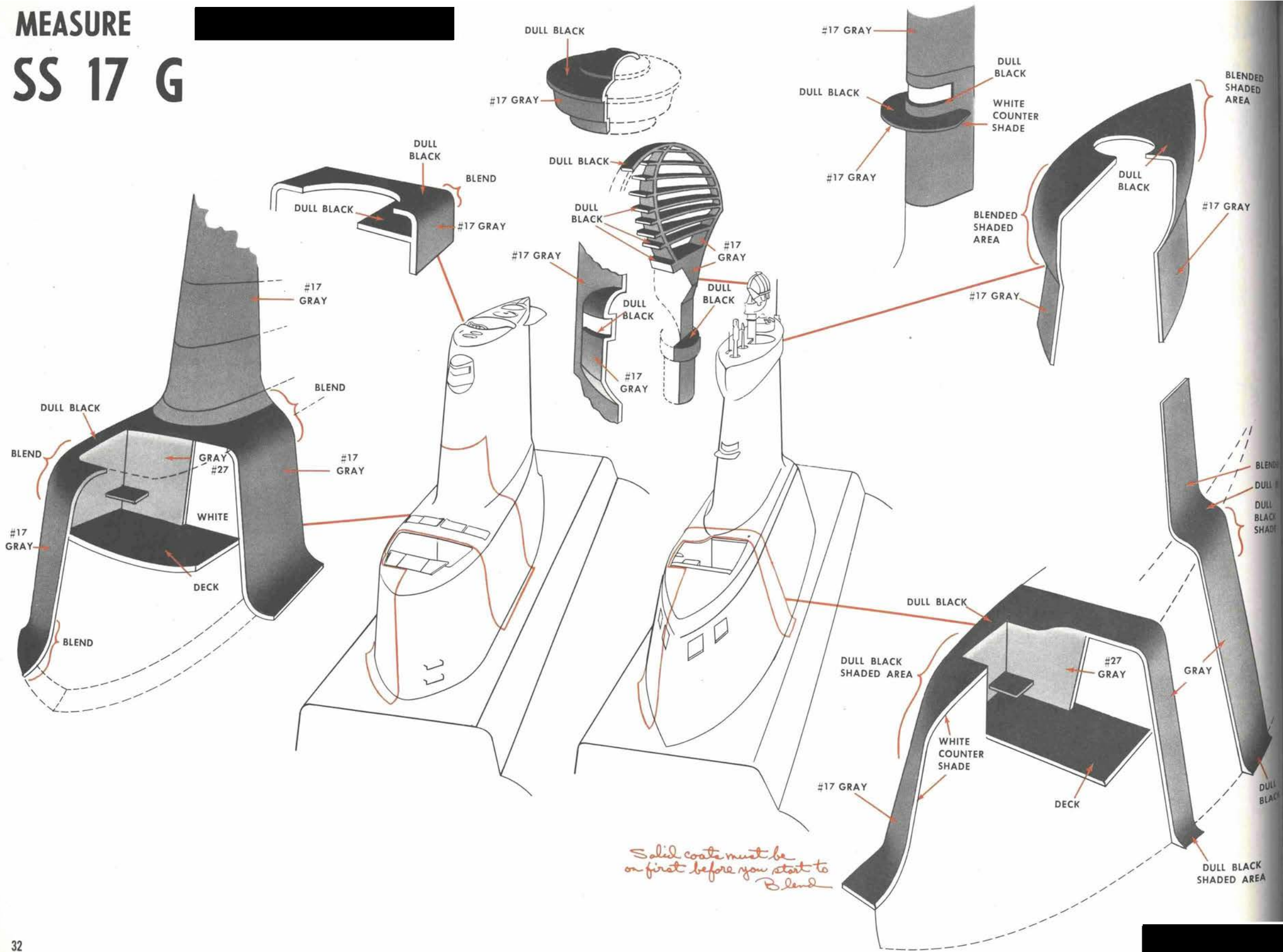

MEASURE SS 17 G

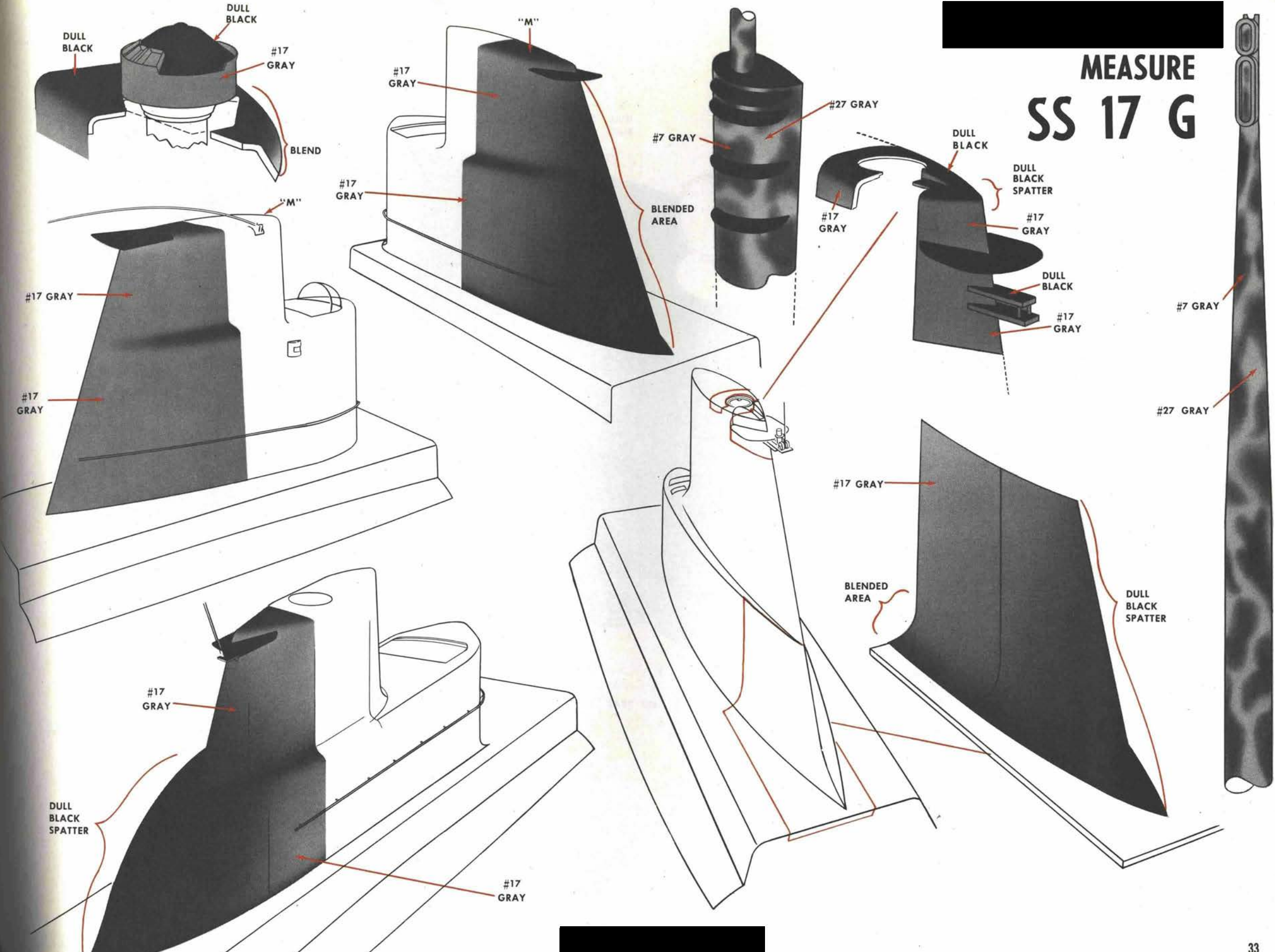

MEASURE SS 17 G

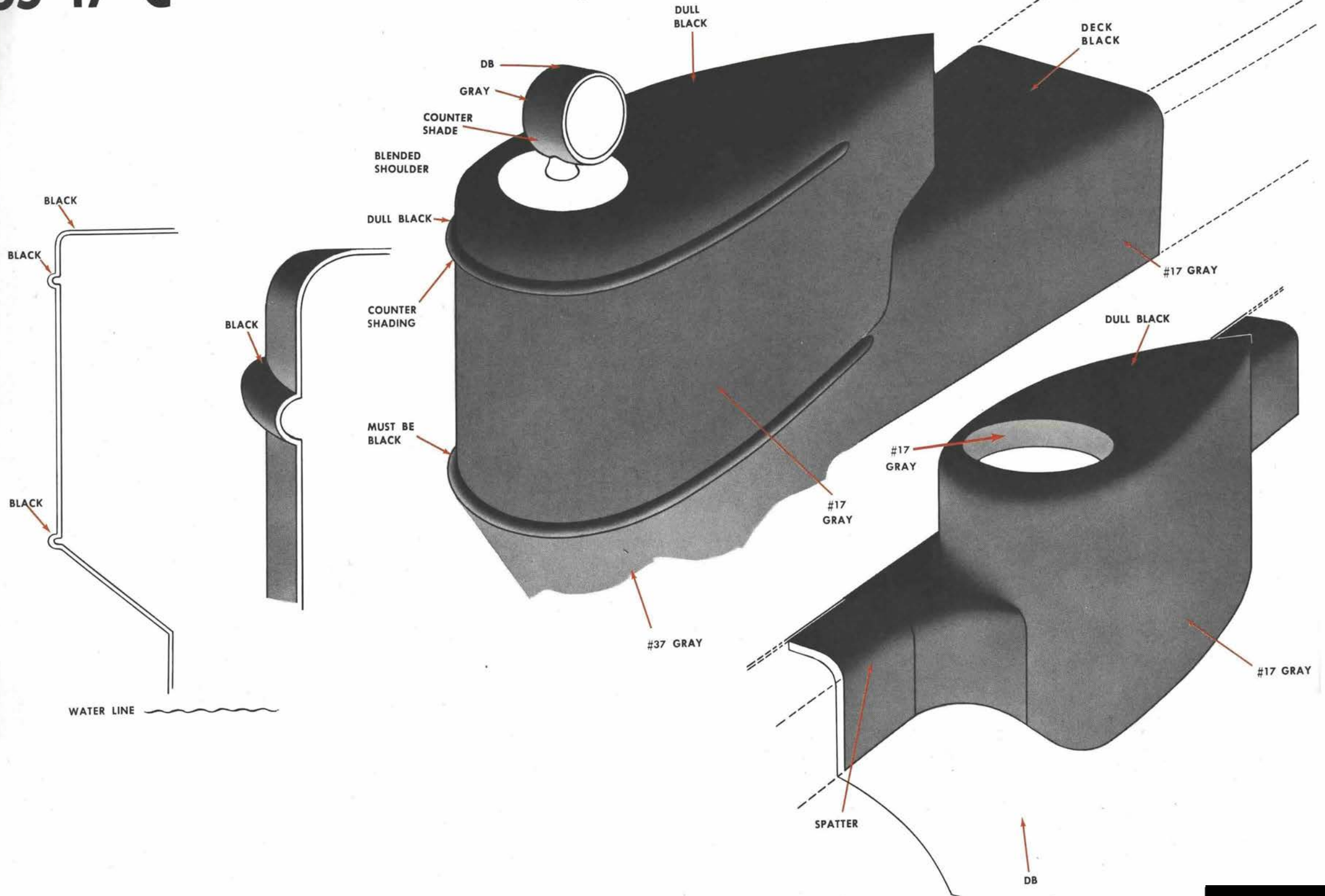

MEASURE SS 11 G

NOTE.—"How To Use a Spray Gun To Get Special Submarine Concealment Effects," pages 20 to 27, shall be required reading for all painters before starting to paint this measure.

(A) Word description. Outside Gray No. 11, Stock No. G52-P-5086-5, is the basic shade for this measure and shall be applied to the vertical sides from the pressure hull to the top-most part of the boat except as hereafter noted and shown on the illustrations for this measure.

Haze Gray (5-H), Stock No. G52-P-961, shall be applied to all of the vertical or nearly vertical surfaces that are inside of the bridge structure and to all surfaces six inches or more inside limber holes that can be reached by a painter stationed near the water line outside the boat, and to the top of the hull that is covered by the superstructure.

Haze Gray (5-H) shall also be used inside the bridge where white or deck black do not apply.

Haze Gray (5-H) shall be applied in solid coat to periscope necks and streamlined periscope fairings as the background shade for the dark spotting.

Navy Gray (5-N), Stock No. G52-P-963, shall be used for the dark spots on periscope necks and fairings. How to paint a periscope is described on page 24 and also illustrated.

Dull Black No. 104 shall be applied to all *rounded* surfaces facing generally upward including the rounded edges of decks, the upturned rounded surfaces of radar, the rounded top of

sonar domes, top of snorkel, all hand rails, the top of the pressure hulls, and tanks between the low water line and superstructure.

Dull Black No. 104 may also be used for making the spatter gradations from dull black areas to lighter areas as illustrated for this measure.

White No. 6, Stock No. G52-P-5305, shall be applied in solid coat to the overhead and to all other areas of the bridge except those portions which may become exposed to the direct rays of the sun.

White No. 6 shall also be applied in solid coat to the shears, braces, sides, and all other stationary surfaces inside the sail up to three feet from the top of the sail. This excludes radar antennae, snorkel, and periscopes.

White No. 6 shall be applied to the interior of the superstructure above the hull and below the main deck (forward of the conning tower) including the under side of the main deck and the interior of the sides. Aft of the conning tower, inside the superstructure, is unimportant. White shall not be applied to the top of the hull, even beneath the main deck.

Snorkel exhaust baffle plates: The *top* of these plates, that is, the horizontal surface which faces upward, shall be painted by brush with Dull Black No. 104, Stock No. G52-P-5075. The

under side of these plates shall be painted by brush with Pure White, Stock No. G52-P-5305.

(B) Effectiveness and Suitability. This measure goes all out for concealment submerged. It accepts the greater possibility of detection on the surface at night, which is a very slim possibility and accepts the greater possibility of surface detection during most of the daylight or twilight. This measure is harder to see also from steep downward angles with the sun behind the observer than measure SS 17 G, the sides of the latter being more reflectant.

On the other hand, this measure is easier to see and can be seen to greater distances than SS 17 G when surfaced at small grazing angles, i. e., to distant or low flying aerial observers searching the horizon. Consequently, there is some appreciable increase in the detection possibility on the surface, near the horizon, over measure SS 17 G. During comparative tests, submarines painted with this measure when sighted were, 97 percent of the time, darker than their background. A more complete study of precisely how far these submarines can be seen both surfaced and submerged under various conditions of light, sea, and weather conditions, from all directions, is gradually drawing to a close and should be completed within the next 6 months. Comparisons are being made with other measures also.

MEASURE

SS 11 G

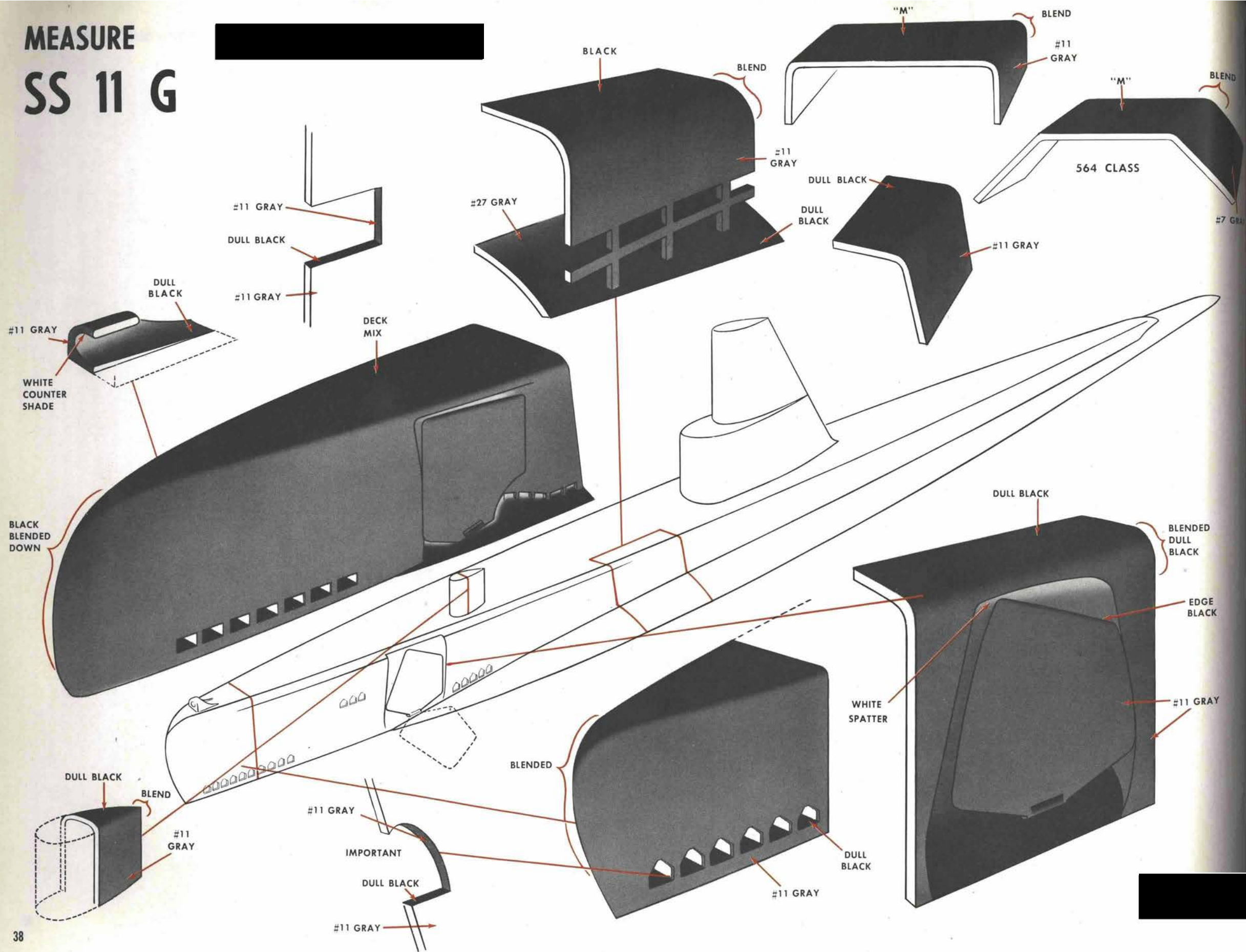

MEASURE SS 11 G

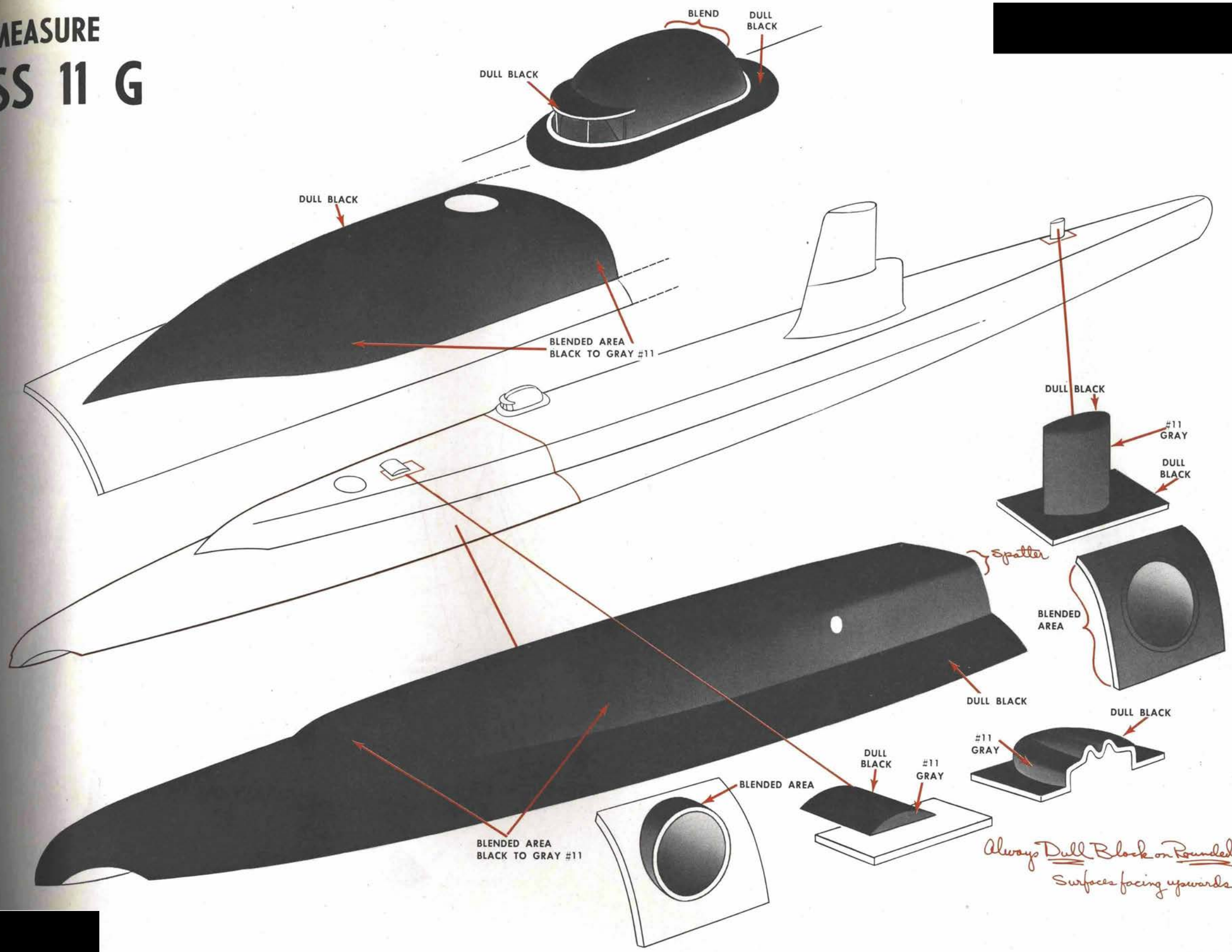

MEASURE SS 11 G

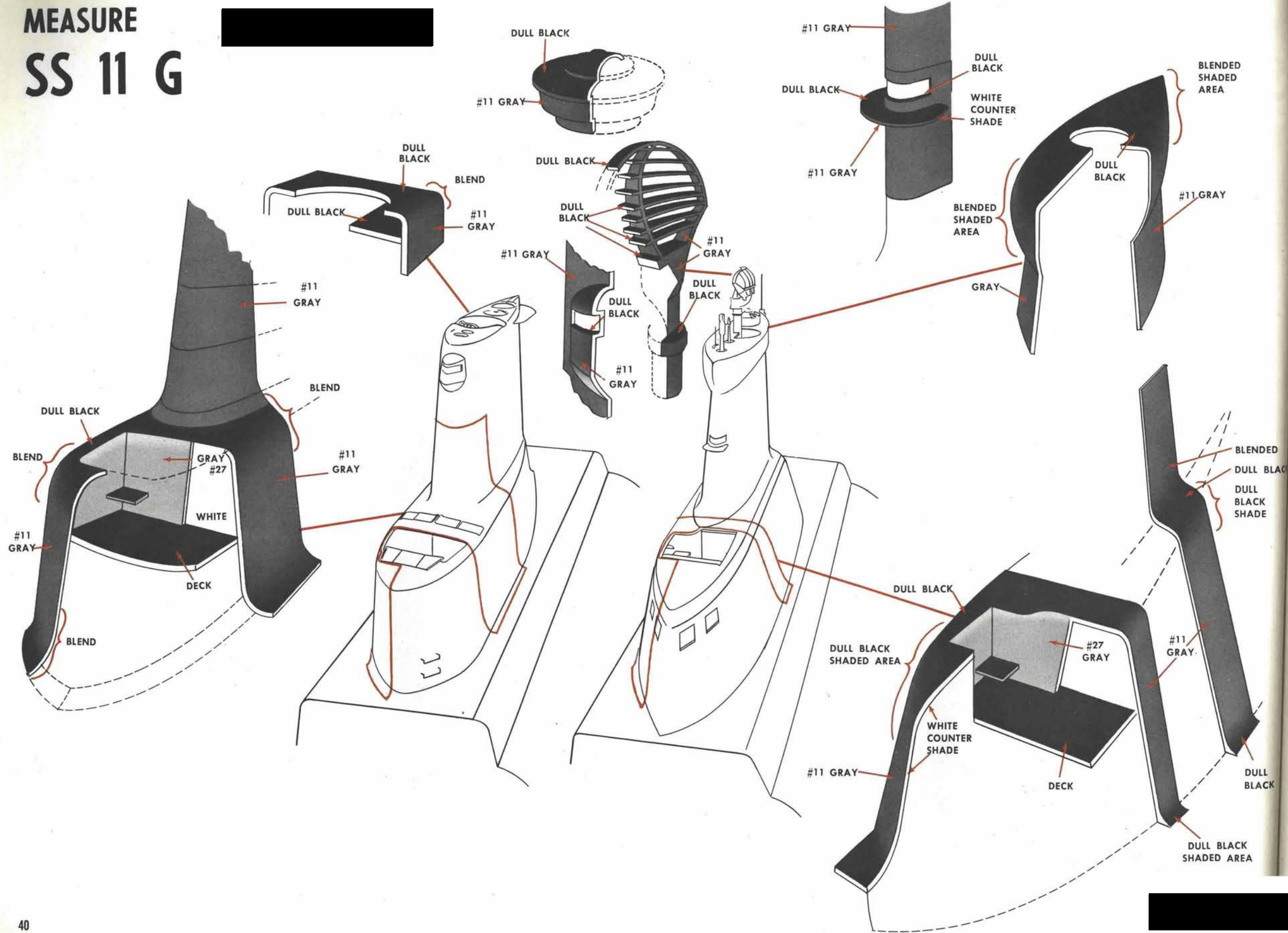

MEASURE SS 11 G

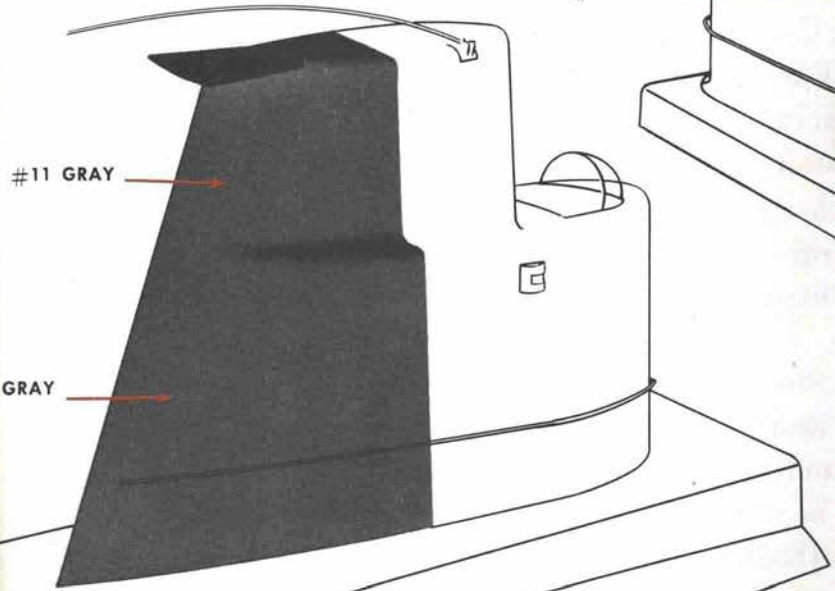
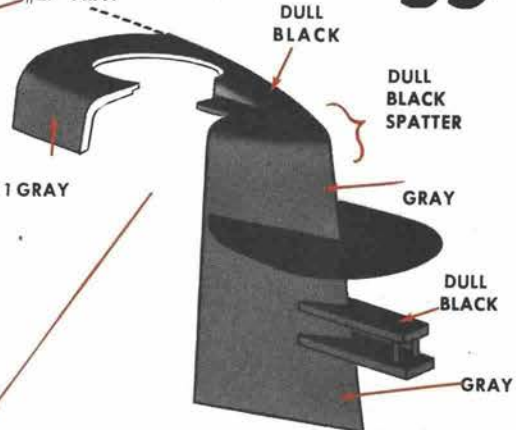
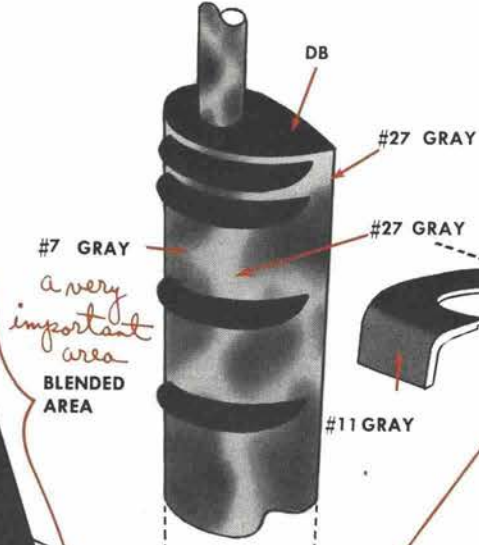
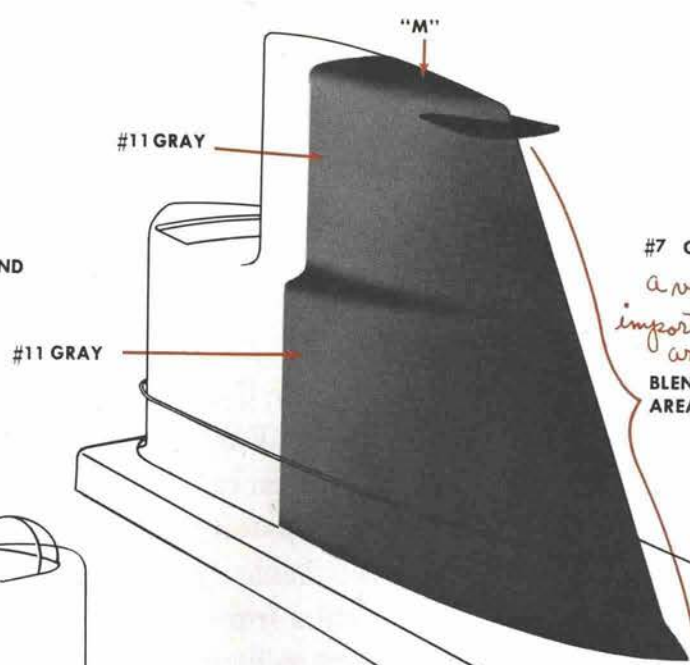
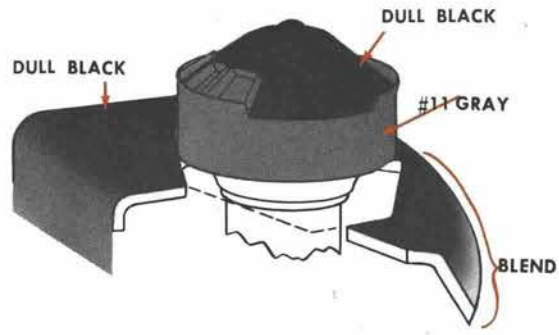

#7 GRAY

#27 GRAY

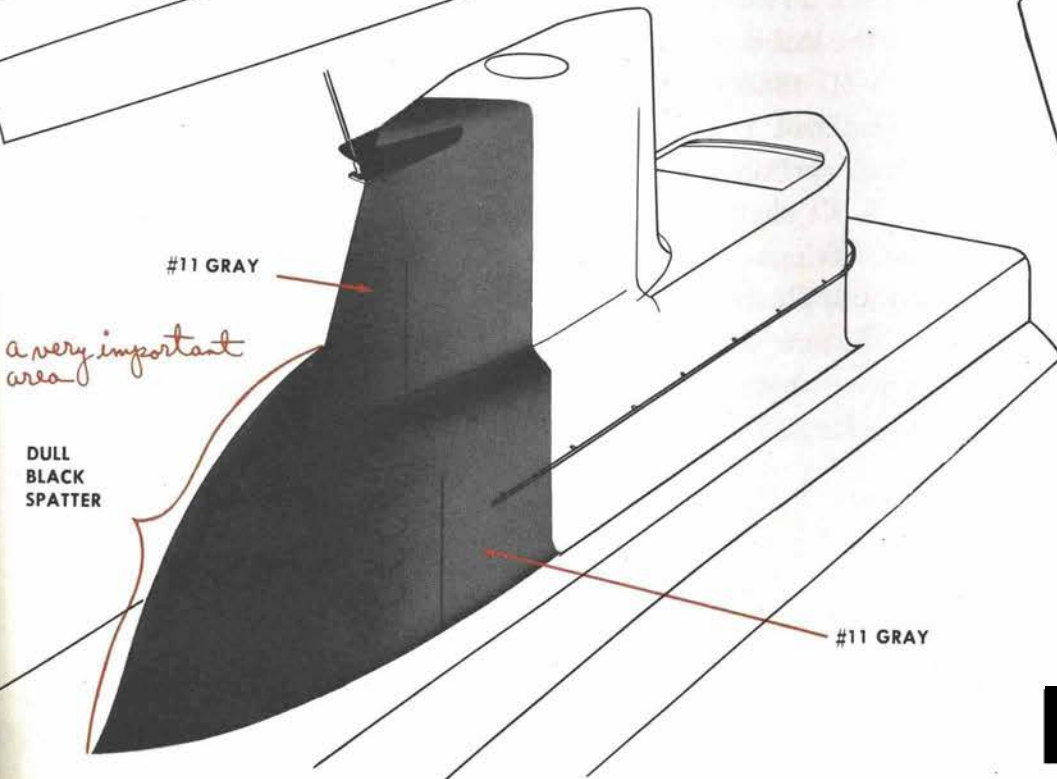
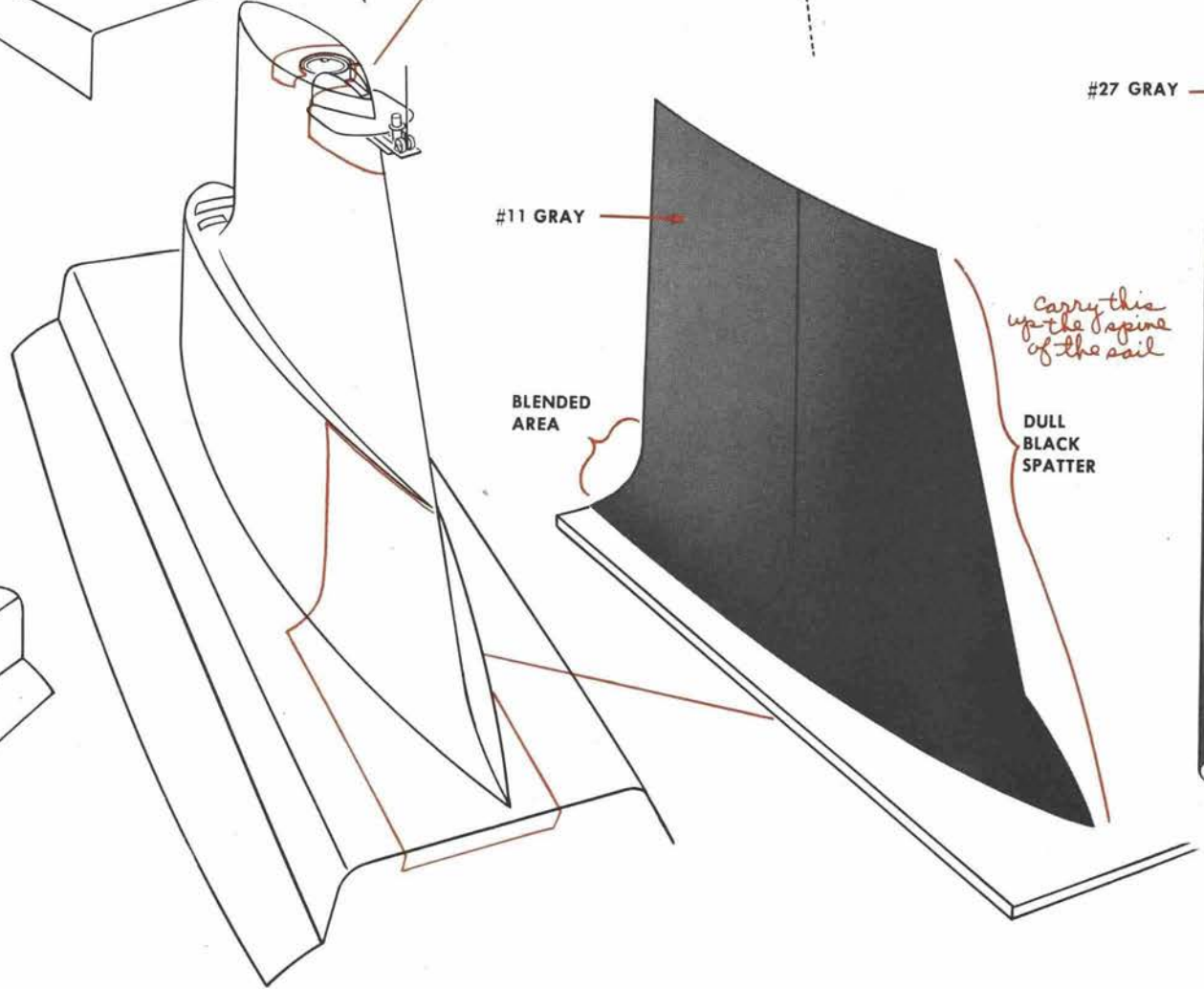

MEASURE SS 7 G

NOTE.—"How To Use a Spray Gun To Get Special Submarine Concealment Effects," pages 20 to 27, shall be required reading for all painters before starting to paint this measure.

(A) Word Description. Navy Gray (5-N) Stock No. G52-P-963, is the basic shade for this measure and shall be applied to the vertical sides from the pressure hull to the topmost part of the boat except as hereafter noted and shown on the illustrations for this measure.

Ocean Gray (5-O), Stock No. G52-P-965, shall be applied to all of the vertical or nearly vertical surfaces that are inside of the bridge structure and to all surfaces 6 inches or more inside limber holes that can be reached by a painter stationed near the water line outside the boat, and to the top of the hull that is covered by the superstructure.

Ocean Gray (5-O) shall also be used inside the bridge where white or deck black do not apply and inside the fairwater "sail" from the top of the sail downward for three feet.

Haze Gray (5-H) shall be applied in solid coat to periscope necks and streamlined periscope fairings, as the background shade for the dark spotting.

Navy Gray (5-N) shall be used for the dark spots on periscope necks and fairings. How to paint periscopes is described on page 24 and also illustrated.

Deck Paint Mixture shall be applied to all decks except on the rounded edges where Dull Black No. 104 is used as later described and illustrated.

Dull Black No. 104 may be applied to all *rounded* surfaces facing generally upward including the rounded edges of decks, the upturned rounded surfaces of radar, the rounded top of sonar domes, top of snorkel, all hand rails, the top of the pressure hulls, and tanks between the low water line and superstructure.

Dull Black No. 104 shall also be used for making the spatter gradations from dull black areas to lighter areas as illustrated for this measure.

Haze Gray (5-H) Stock No. G52-P-961, shall be applied in solid coat to the overhead and to all other areas of the bridge except those portions which may become exposed to the direct rays of the sun.

Haze Gray (5-H) shall also be applied in solid coat to the shears, braces, sides, and all other stationary surfaces inside the sail up to three feet from the top of the sail. This excludes radar antennae, snorkel, and periscopes.

Snorkel exhaust baffle plates: The top of these plates, that is, the horizontal surface which faces upward, shall be painted by *brush* with dull black No. 104, Stock No. G52-P-5075. The *under* side of these plates shall be painted by *brush* with pure white, Stock No. G52-P-5305.

(B) Effectiveness and Suitability. This is another, and possibly the best, all-out submerged measure, although the superior effectiveness of this measure over SS 11 G has not been clearly established. *However, it is believed to be superior to any other measure in the one condition under which submarines have*

been followed to maximum depth, namely, under the most favorable conditions for sighting which includes smooth sea, sun's altitude between 50° and 70°, clear deep water, and with the observer looking steeply downward (50° to 70°) with the sun behind the observer. Under the conditions described, submarines painted with this measure are harder to see than with any other painting known, and are lost to view generally around 75 feet keel depth or before. Looking toward the sun this does not hold. This measure is too dark and stands out in silhouette and, of course, *it is much too dark for any surface operation.*

Under very moderate sea, no white caps and variously described as state one and one plus, but with other conditions as described above, neither the writer nor his pilot was able to sight a boat so painted after it was seen to go completely under. This was repeated on several occasions.

Again attention is invited to the fact that boats painted with 17 or 11 percent reflectant paints on their sides as in SS 17 G and SS 11 G, respectively, are very hard to see submerged also, and almost never are sighted, except under ideal sighting conditions. Since this measure goes to such an extreme to achieve maximum concealment submerged against the one worst condition, it appears doubtful that its adoption for general use is the best policy, for this gain cannot be had without additional risk to the boat on the surface where it is much more likely to be sighted either at night, twilight, or in the daytime.

MEASURE SS 7 G

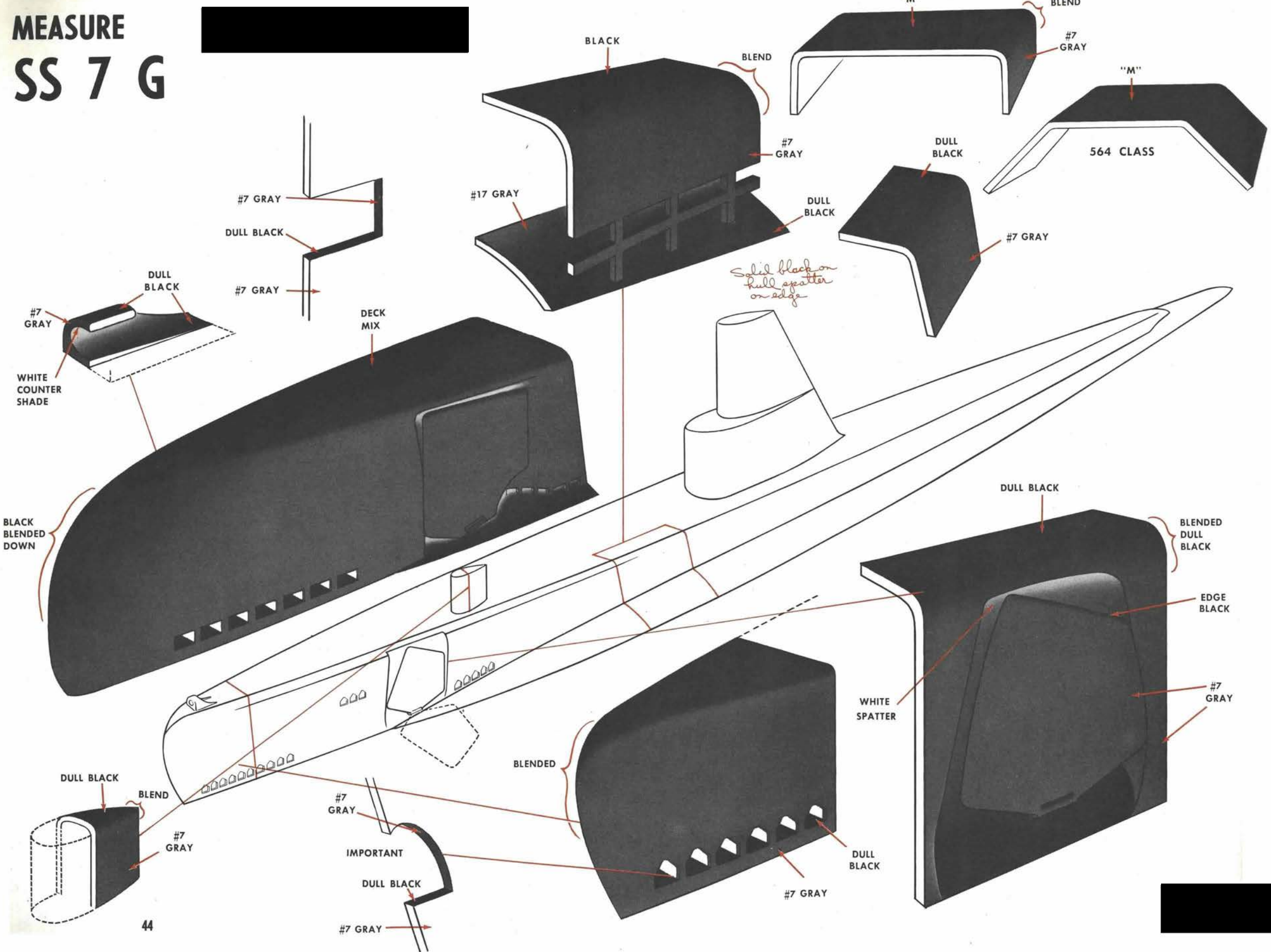

MEASURE SS 7 G

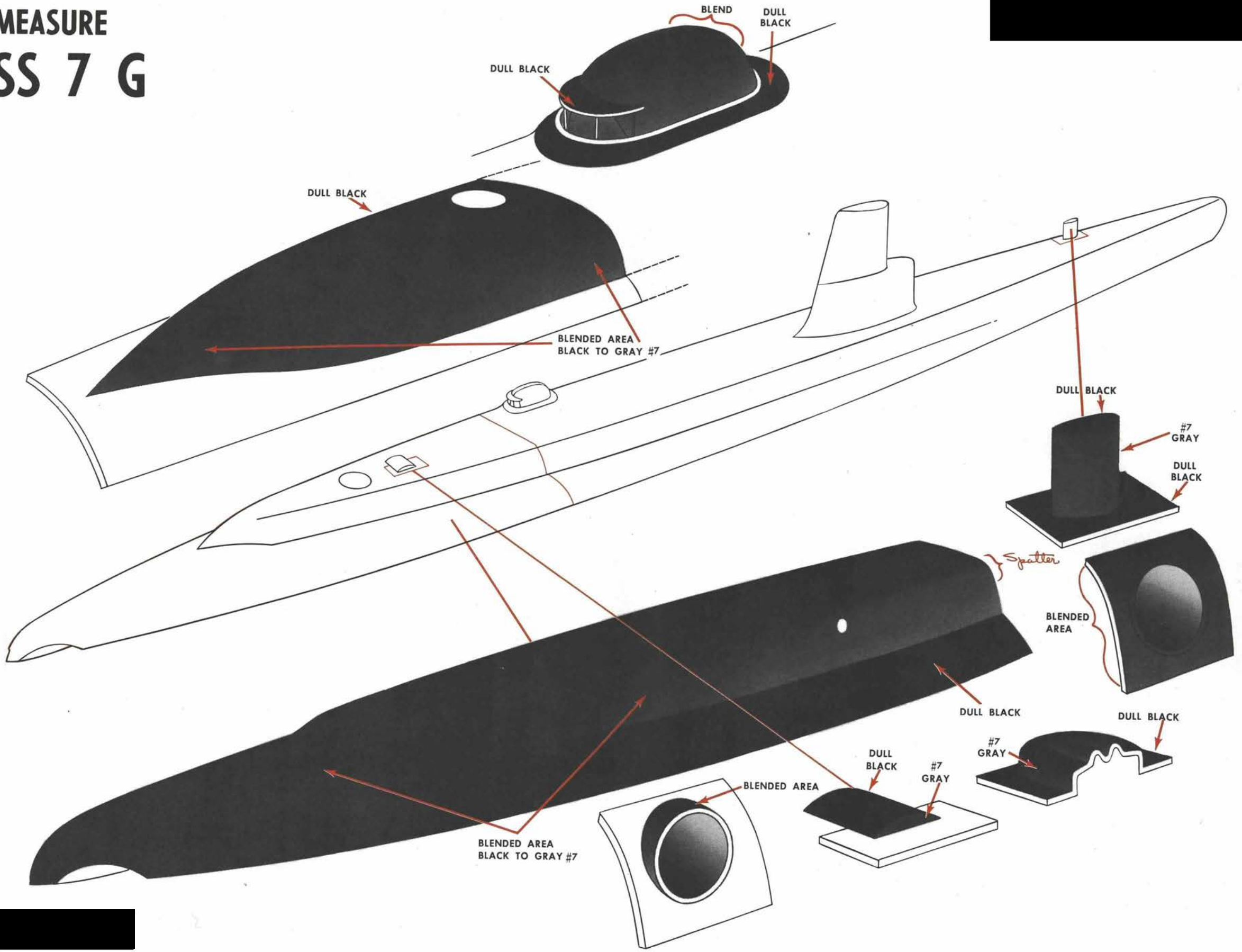

MEASURE

SS 7 G

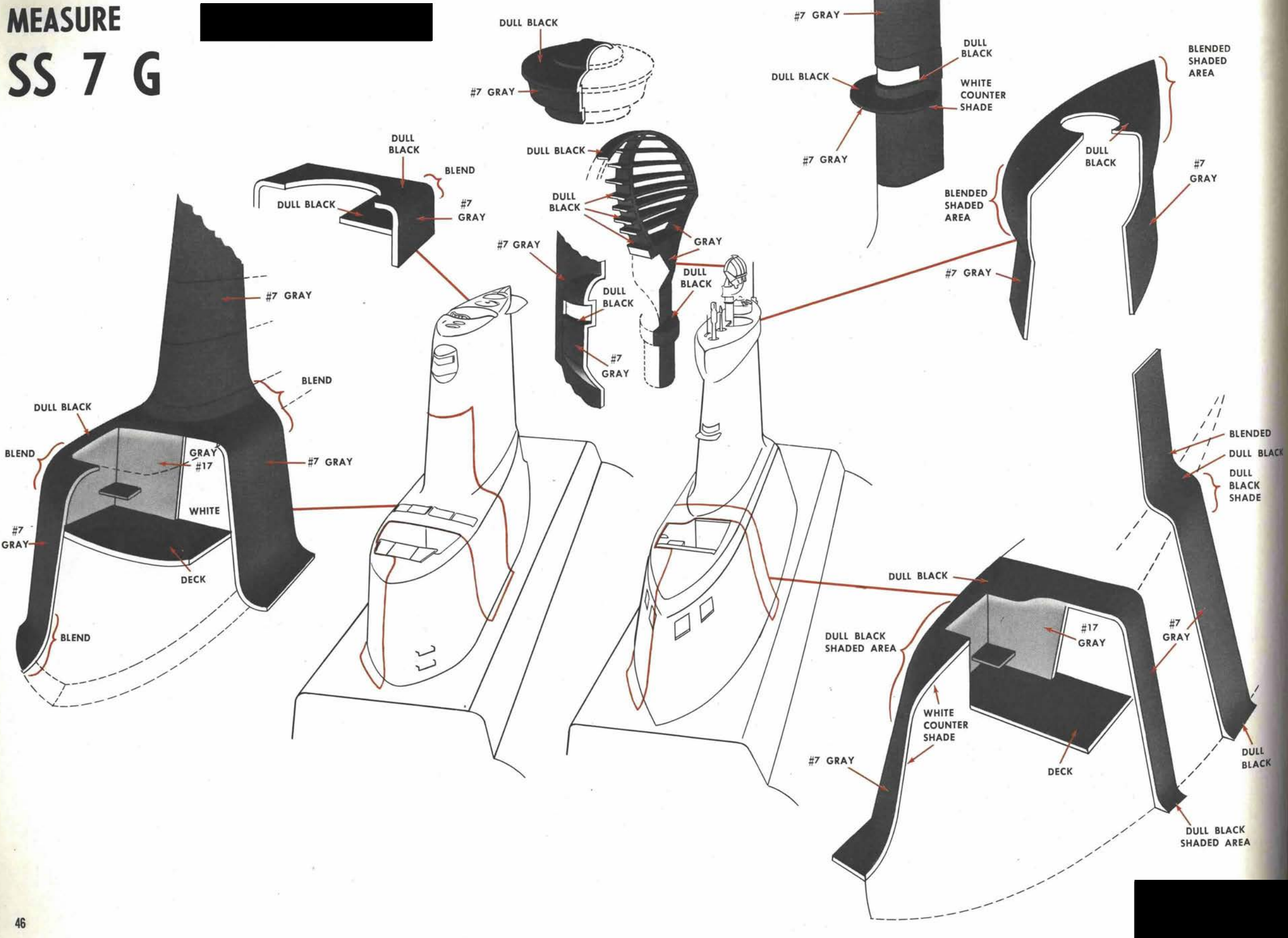



MEASURE SS 7 G

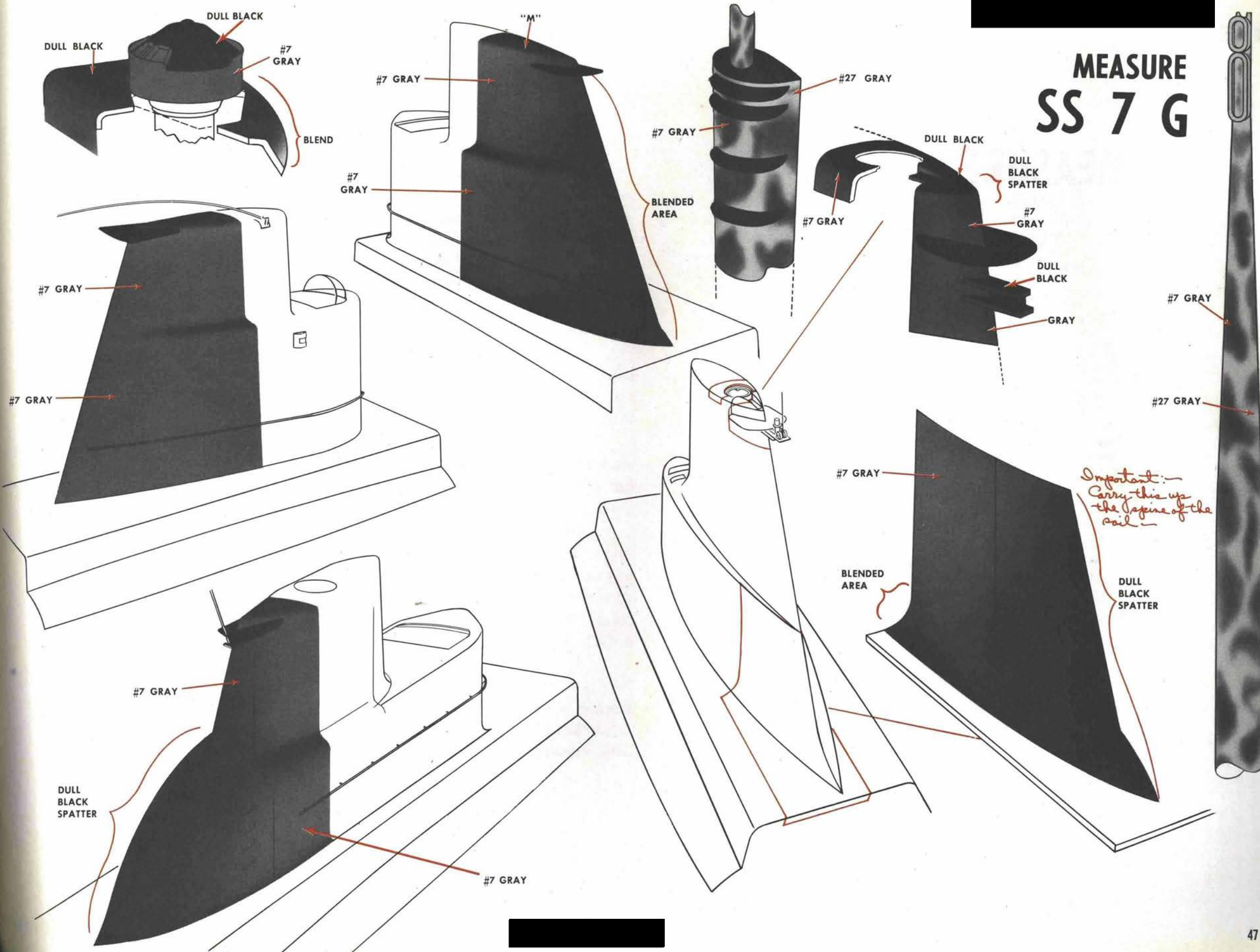

MEASURE SS 27 O

NOTE.—"How to Use a Spray Gun to Get Special Submarine Concealment Effects," pages 20 to 27, shall be required reading for all painters before starting to paint this measure.

(A) Word Description. Haze Gray (5-H), Stock No. G52-P-961, is the basic shade for this measure and shall be applied to the vertical sides from the pressure hull to the topmost part of the boat except as hereafter noted and shown on the illustrations for this measure.

Haze Gray (5-H) shall be applied to all of the vertical or nearly vertical surfaces that are inside of the bridge structure and to all surfaces six inches or more inside limber holes that can be reached by a painter stationed near the water line outside the boat, and to the top of the hull that is covered by the superstructure.

Haze Gray (5-H) shall also be used inside the bridge where white or deck black do not apply and inside the fairwater "sail" from the top of the sail downward for 3 feet.

Haze Gray (5-H) shall be applied in solid coat to periscope necks and streamlined periscope fairings as the background shade for the dark spotting.

Navy Gray (5-N) Stock No. G52-P-963, shall be used for the dark spots on periscope necks and fairings. How to paint periscopes is described on page 24 and also illustrated.

Deck Paint Mixture shall be applied to all decks except on the rounded edges where Dull Black No. 104 is used as later described and illustrated.

Dull Black No. 104 may be applied to all *rounded* surfaces facing generally upward including the rounded edges of decks, the upturned rounded surfaces of radar, the rounded top of sonar domes, top of snorkel, all hand rails, the top of the pressure hulls, and tanks between the low water line and superstructure.

Dull Black No. 104 shall also be used for making the spatter gradations from dull black areas to lighter areas as illustrated for this measure.

White No. 6, Stock No. G52-P-5305, shall be applied in solid coat to the overhead and to all other areas of the bridge except those portions which may become exposed to the direct rays of the sun.

White No. 6, shall also be applied in solid coat to the shears, braces, sides, and all other stationary surfaces inside the sail up to three feet from the top of the sail. This excludes radar antennae, snorkel, and periscopes.

White No. 6 shall be applied to the interior of the superstructure above the hull and below the main deck (forward of the conning tower), including the under side of the main deck and the interior of the sides. Aft of the conning tower, inside the superstructure, is important. White shall *not* be applied to the top of the hull, even beneath the main deck.

Snorkel exhaust baffle plates: The *top* of these plates, that is, the horizontal surface which faces upward, shall be painted by *brush* with Dull Black No. 104, Stock No. G52-P-5075. The *under* side of these plates shall be painted by brush with pure white, Stock No. G52-P-5305.

(B) Effectiveness and Suitability. Although the ranges to which this boat may be seen have not been measured, the basic shade is the same as that of SS 27 F which has been measured. The effectiveness of this measure should be very similar to that described for measure SS 27 F on page 55.



MEASURE

SS 27 0

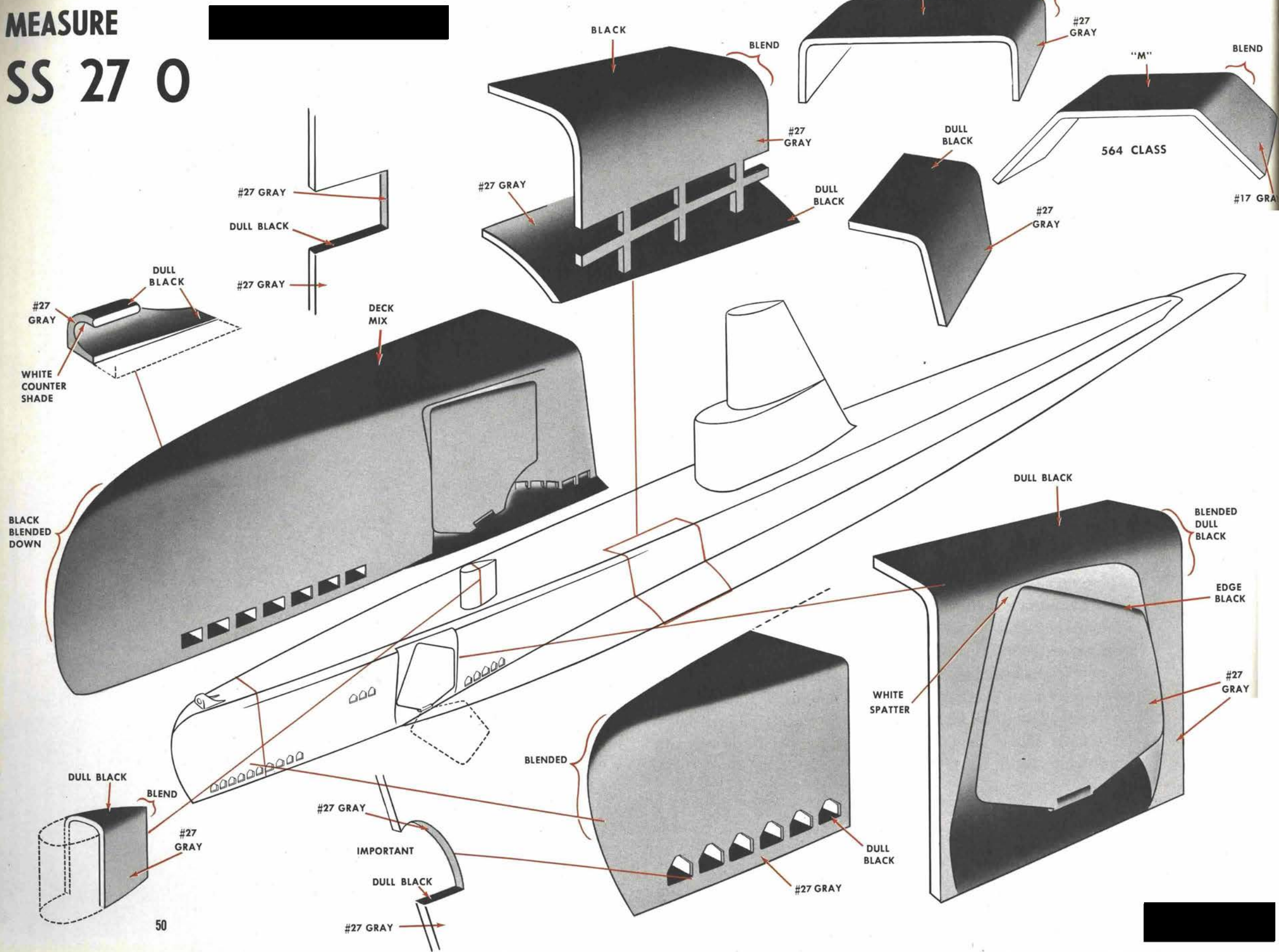

MEASURE SS 27 0

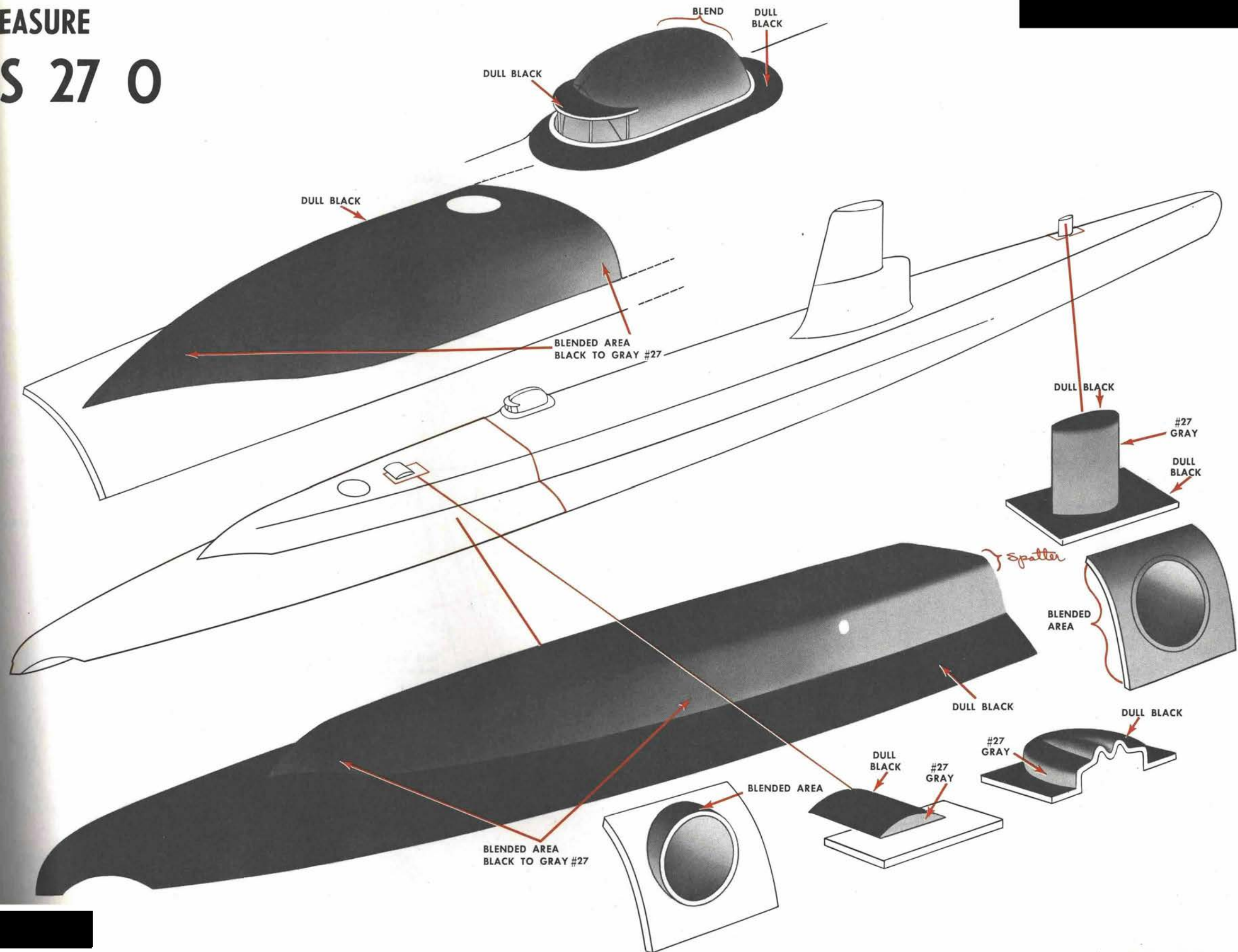

MEASURE

SS 27 0

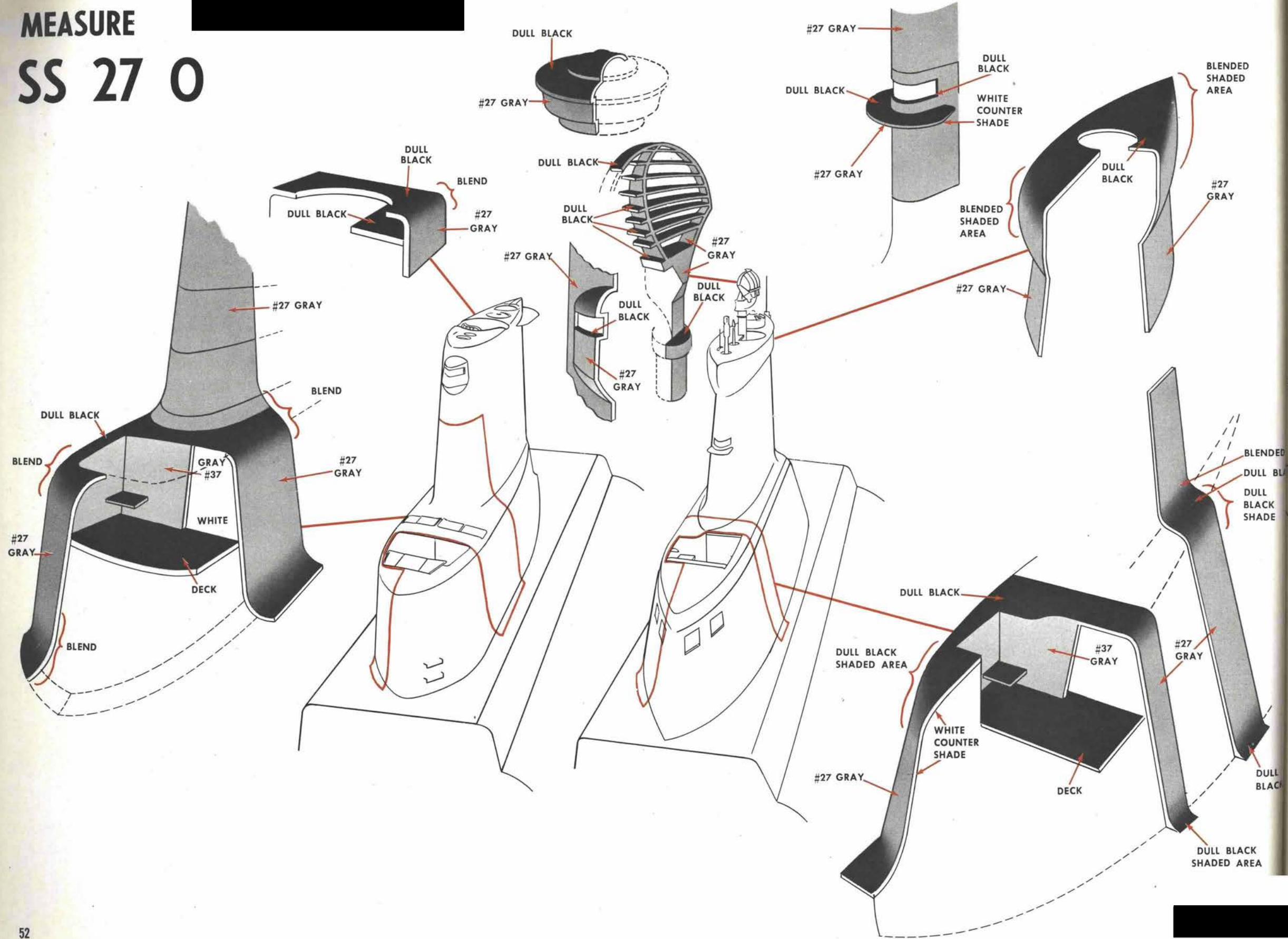

MEASURE SS 27 0

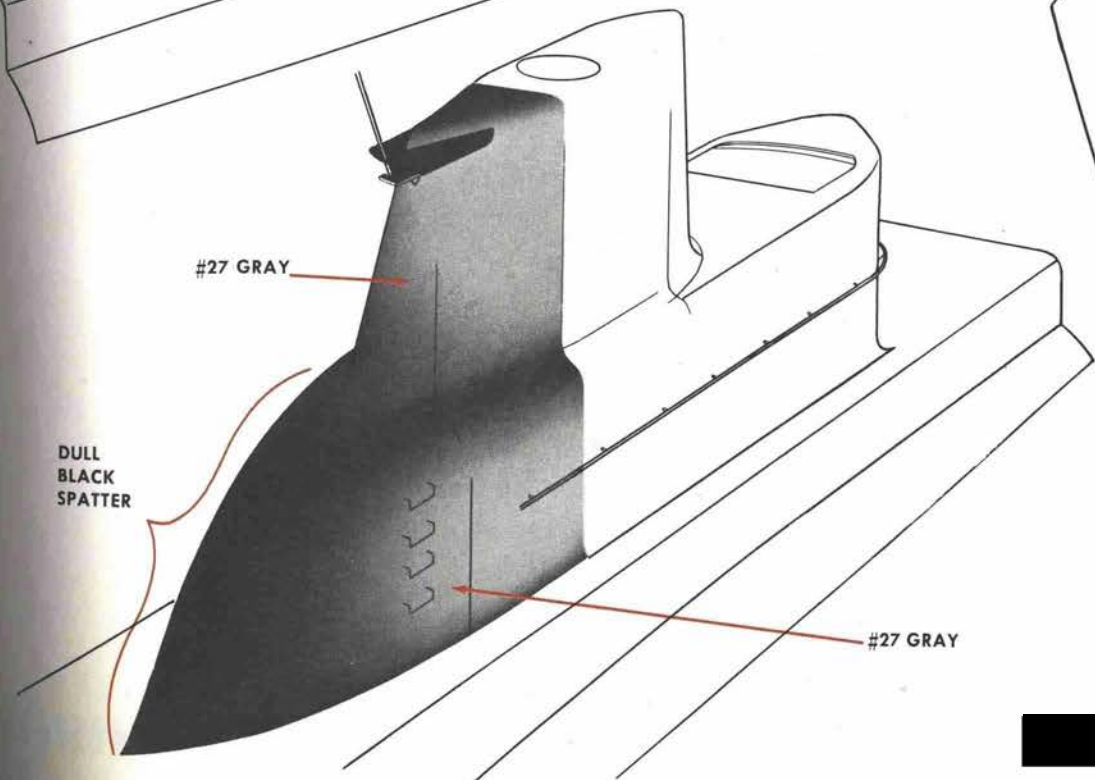
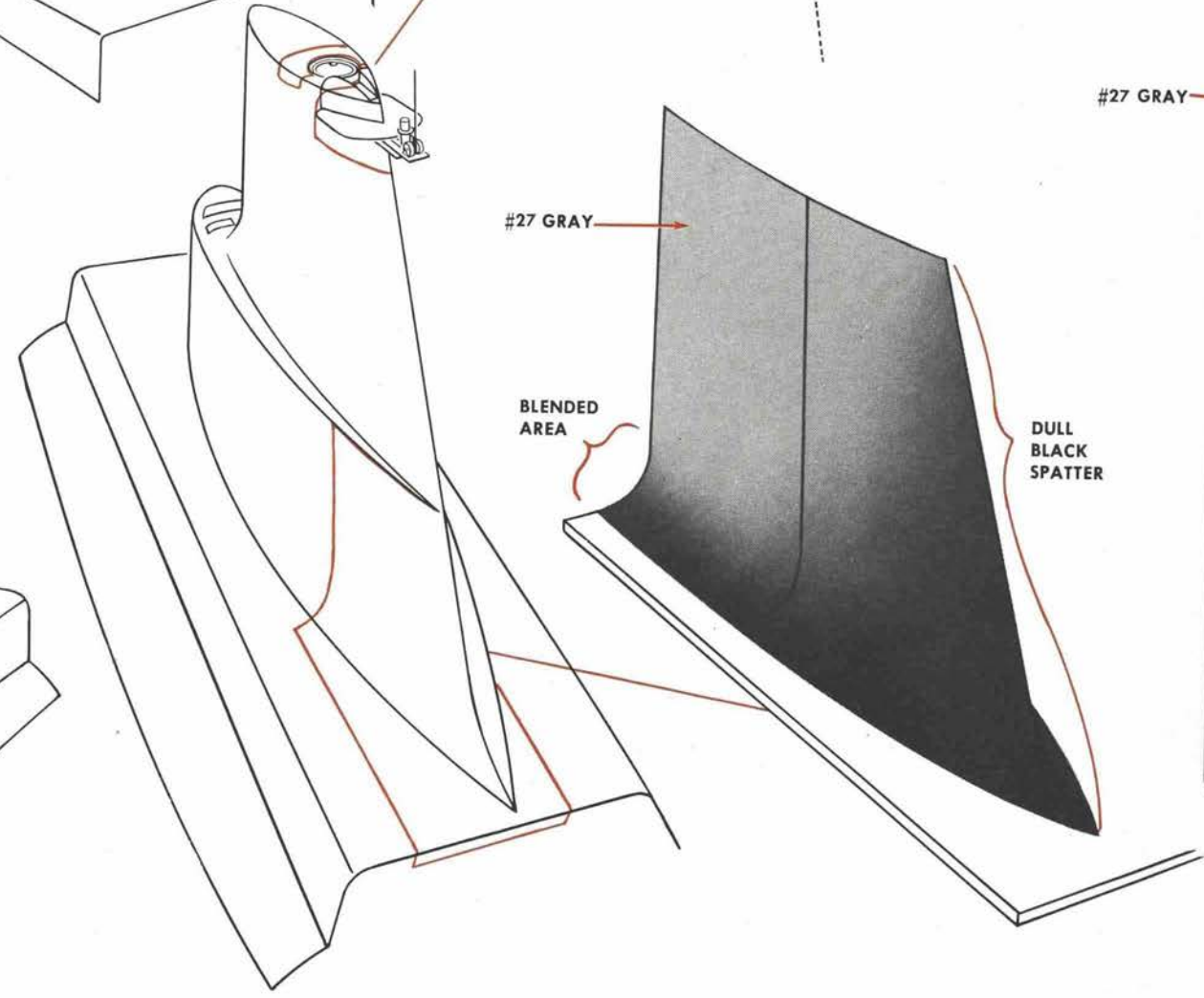
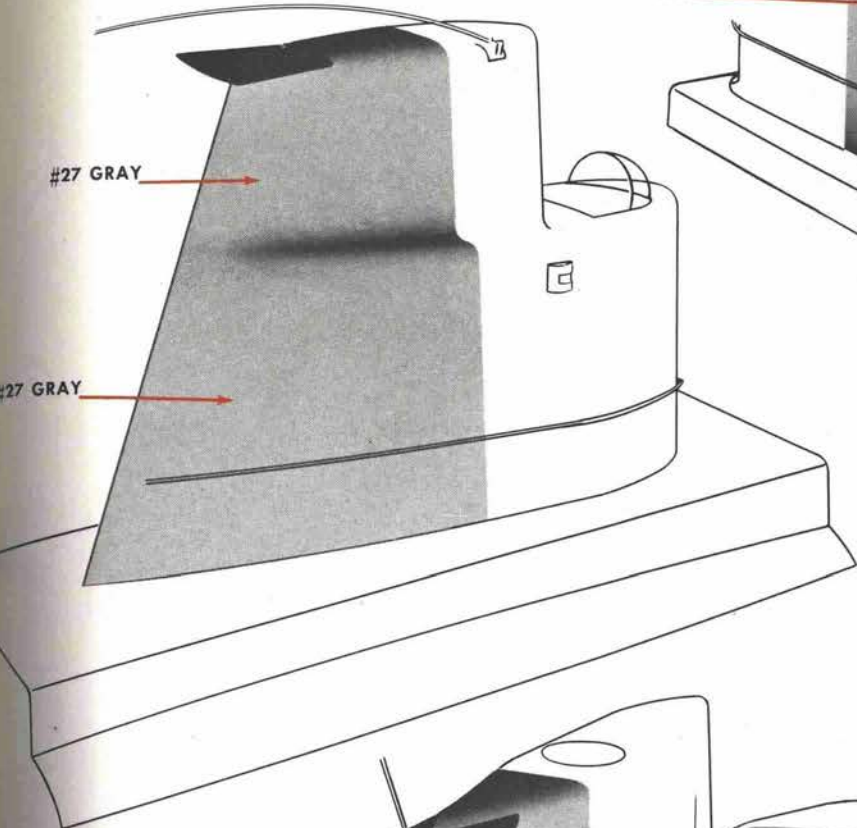
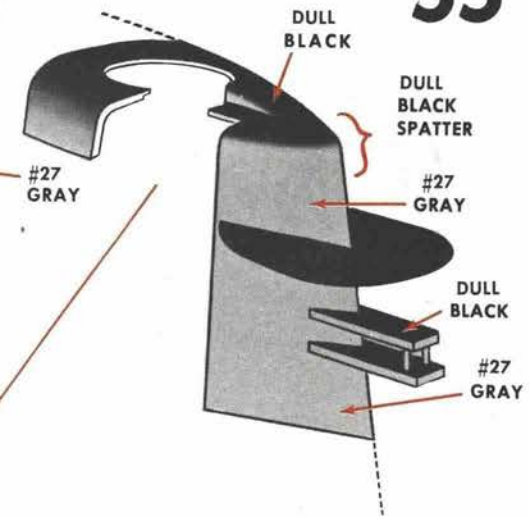
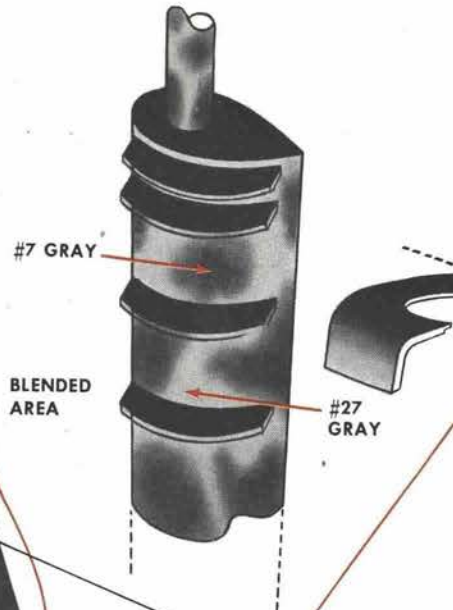
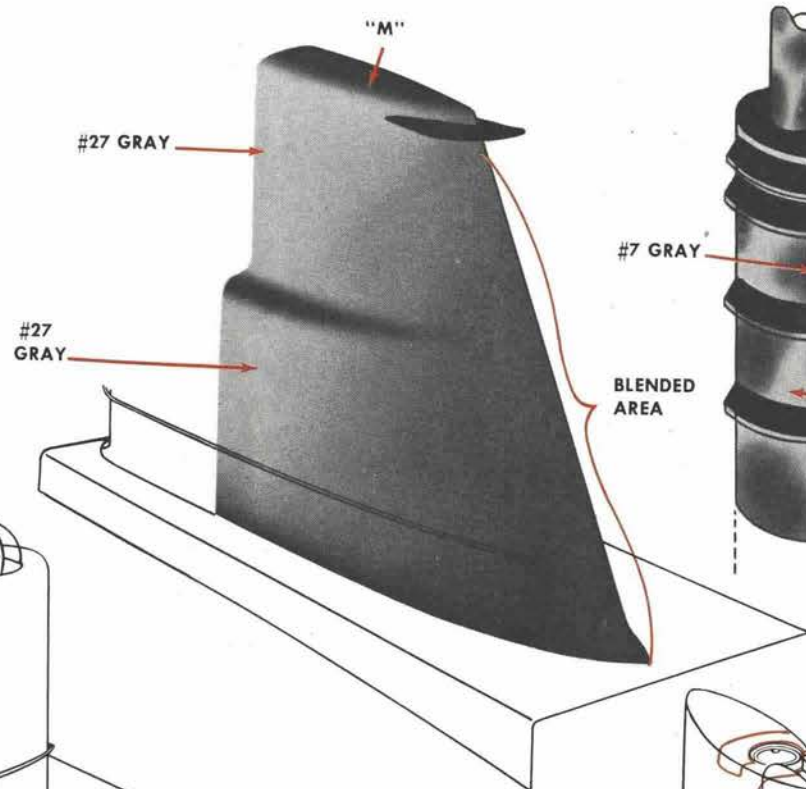
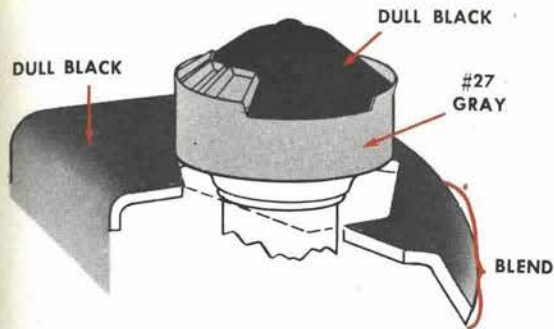

MEASURE SS 27 F

WITH DETAILS TO COVER CARGO, GUIDED MISSILE, AND TRANSPORT SUBMARINES

NOTE.—“How to Use a Spray Gun to Get Special Submarine Concealment Effects,” pages 20 to 27, shall be required reading for all painters before starting to paint this measure.

(A) **Word Description.** Haze Gray (5-H), Stock No. G52-P-961, is the basic shade for this measure and shall be applied to the vertical sides from the pressure hull to the topmost part of the boat except as hereafter noted and shown on the illustrations for this measure.

Haze Gray (5-H) shall be applied to all of the vertical or nearly vertical surfaces that are inside of the bridge structure and to all surfaces six inches or more inside limber holes that can be reached by a painter stationed near the water line outside the boat, and to the top of the hull that is covered by the superstructure.

Haze Gray (5-H) shall also be used inside the bridge where white or deck black do not apply.

Haze Gray (5-H) shall be applied in solid coat to periscope necks and streamlined periscope fairings as the background shade for the dark spotting.

Navy Gray (5-N) Stock No. G52-P-963, shall be used for the dark spots on periscope necks and fairings. How to paint periscopes is described on page 24 and also illustrated.

Deck Paint Mixture shall be applied to all decks except on the rounded edges where Dull Black No. 104 is used as later described and illustrated.

Dull Black No. 104 shall be applied to all *rounded* surfaces facing generally upward including the rounded edges of decks, the upturned rounded surfaces of radar, the rounded top of sonar domes, top of snorkel, all hand rails, the top of the pressure hulls, and tanks between the low water line and superstructure.

Dull Black No. 104 may also be used for making the spatter gradations from dull black areas to lighter areas as illustrated for this measure.

White No. 6, Stock No. G52-P-5305, shall be applied in solid coat to the overhead and to all other areas of the bridge except those portions which may become exposed to the direct rays of the sun.

White No. 6 shall be applied to the interior of the superstructure above the hull and below the main deck (forward of the conning tower) including the under side of the main deck and the interior of the sides. White shall *not* be applied to the top of the hull, even beneath the main deck.

Snorkel exhaust baffle plates: The *top* of these plates, that is, the horizontal surface which faces upward, shall be painted by *brush* with Dull Black No. 104, Stock No. G52-P-5075. The *under* side of these plates shall be painted by *brush* with pure white, Stock No. G52-P-5305.

Hangars and other details as applicable to cargo, guided missile, and transport submarines shall be painted as shown on illustrations by techniques described in section 3b.

(B) Effectiveness and Suitability. This measure (formerly listed in NavShips 250-631 as No. 32/3SSB) is applicable to Fleet-type submarines. (Measure SS 27 F uses the newer deck paint mixture; otherwise measure SS 27 F is identical to 32/3SSB.)

Designed primarily for NIGHT SURFACE attacks, submarines using this measure have a 50-50 chance of being undetected visually on the surface on clear starlit nights at 700

yards to the unaided eye and at 1,600 yards to lookouts using 7 x 50 binoculars. On overcast days when there is moderate surface haze, ships' lookouts and low flying aircraft have great difficulty in visually detecting this measure against the sea background beyond four or five miles. During periods of early evening twilight these submarines when surfaced are extremely hard to detect visually against an eastern sky background but readily detectable against a western sky background.

Under conditions favorable to seeing, submarines using this measure are clearly detectable at periscope depth and below. On a clear sunny day when the sea was glassy smooth and the deep water off the Kauna Coast of the Island of Hawaii was relatively clear, a Fleet-type submarine painted in this manner was followed to a keel depth of 110 feet. (In company with this boat, another painted with measure 32/9SS, now specified as SS 17 F, was lost to view beyond 90 feet and the third boat, painted black all over, was followed visually to 150 feet.) The maximal sightings were made on the two gray boats from the open hatch of a PBY-5A flying at 1,000 feet altitude with the sun behind the observer. When the sun was somewhat in front of the observer neither of the gray boats could be seen at those depths, i. e., 110 and 90 feet, respectively. On the other hand, the black boat, though much less conspicuous than the lighter gray boats at 65 and 90 feet, was also visible at those levels and was followed down to 150 feet, where its dark, shadowy presence could be clearly detected with the sun somewhat in front of the observer.

MEASURE SS 27 F

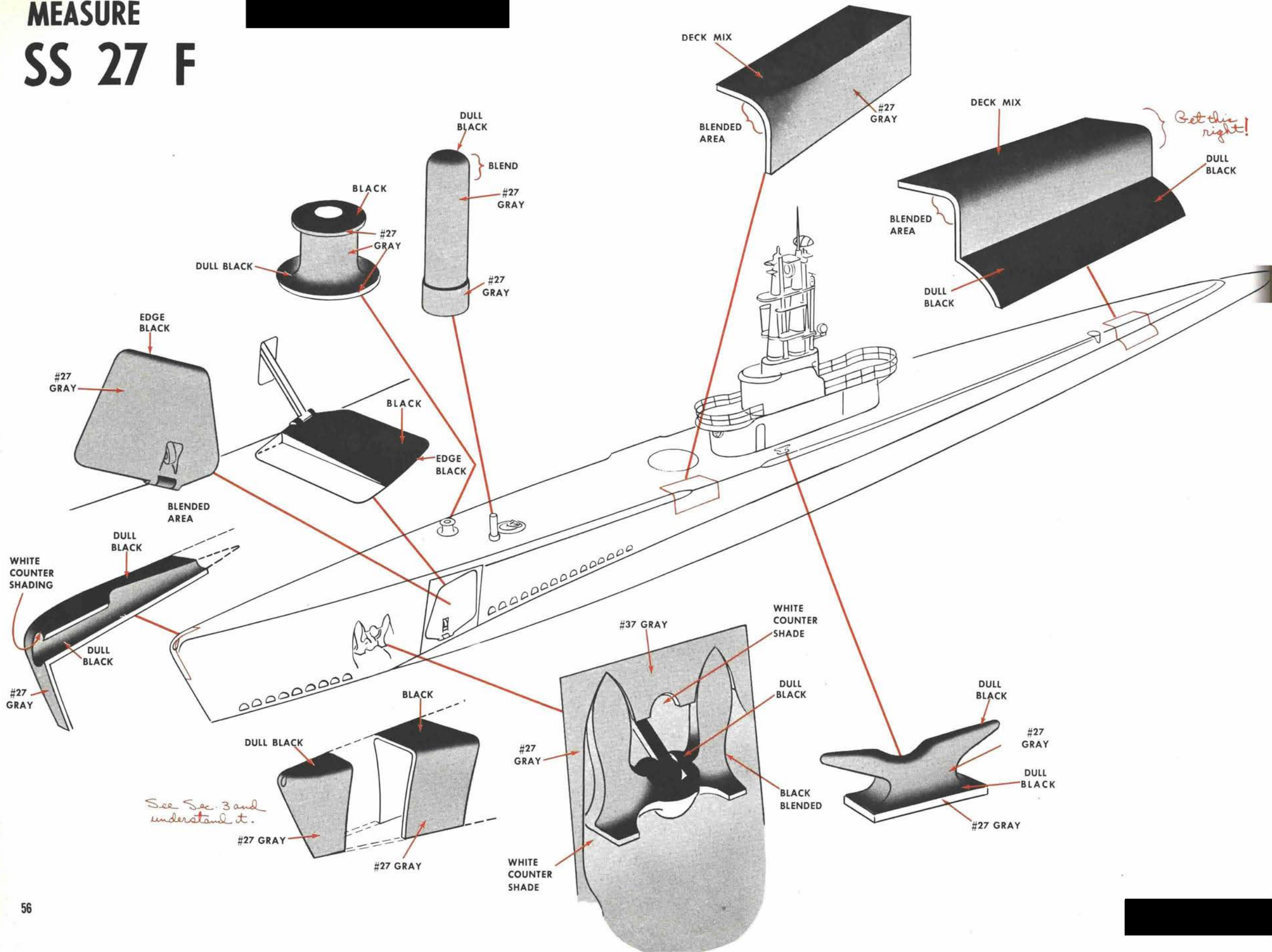

MEASURE SS 27 F

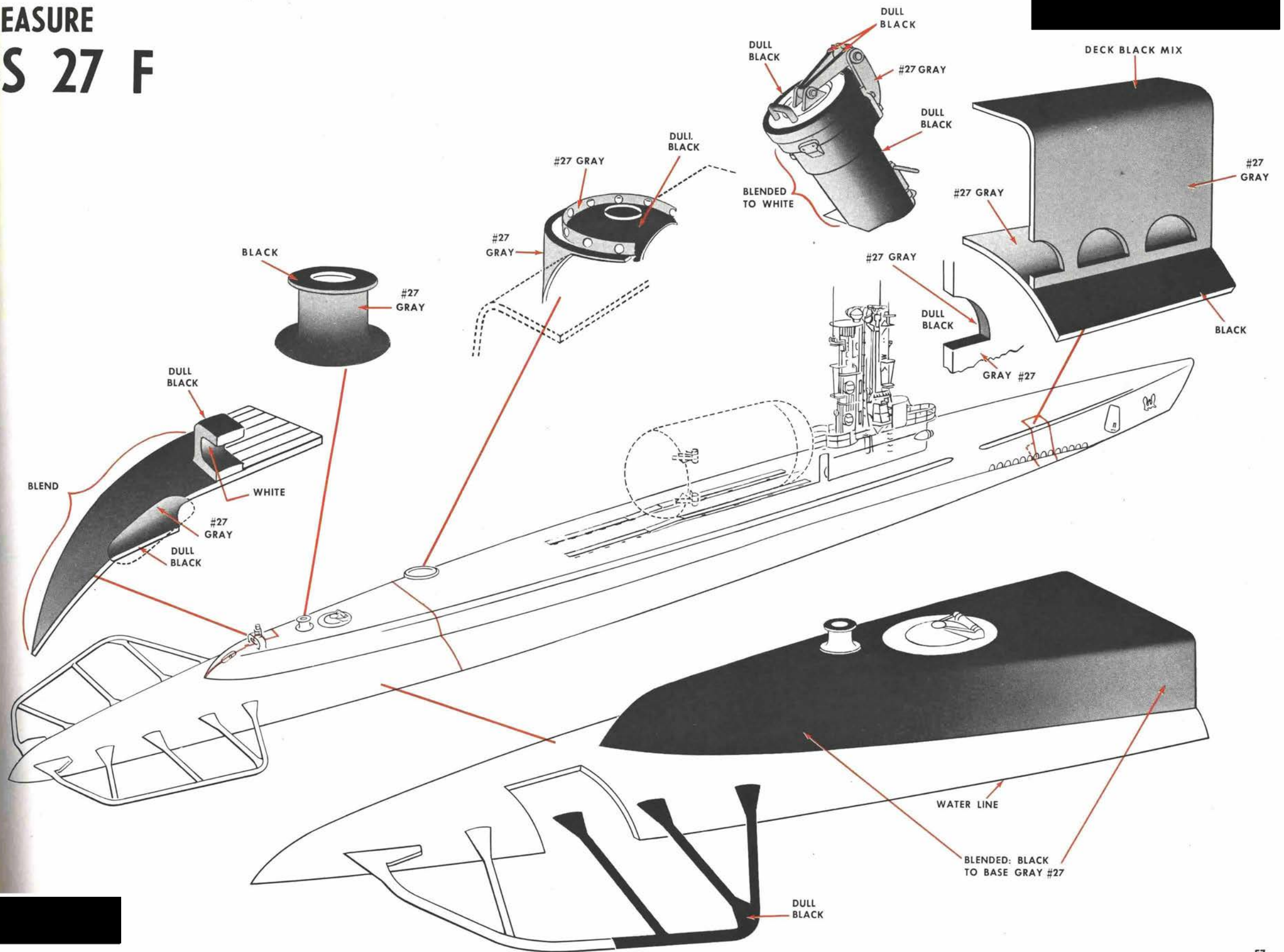

MEASURE SS 27 F

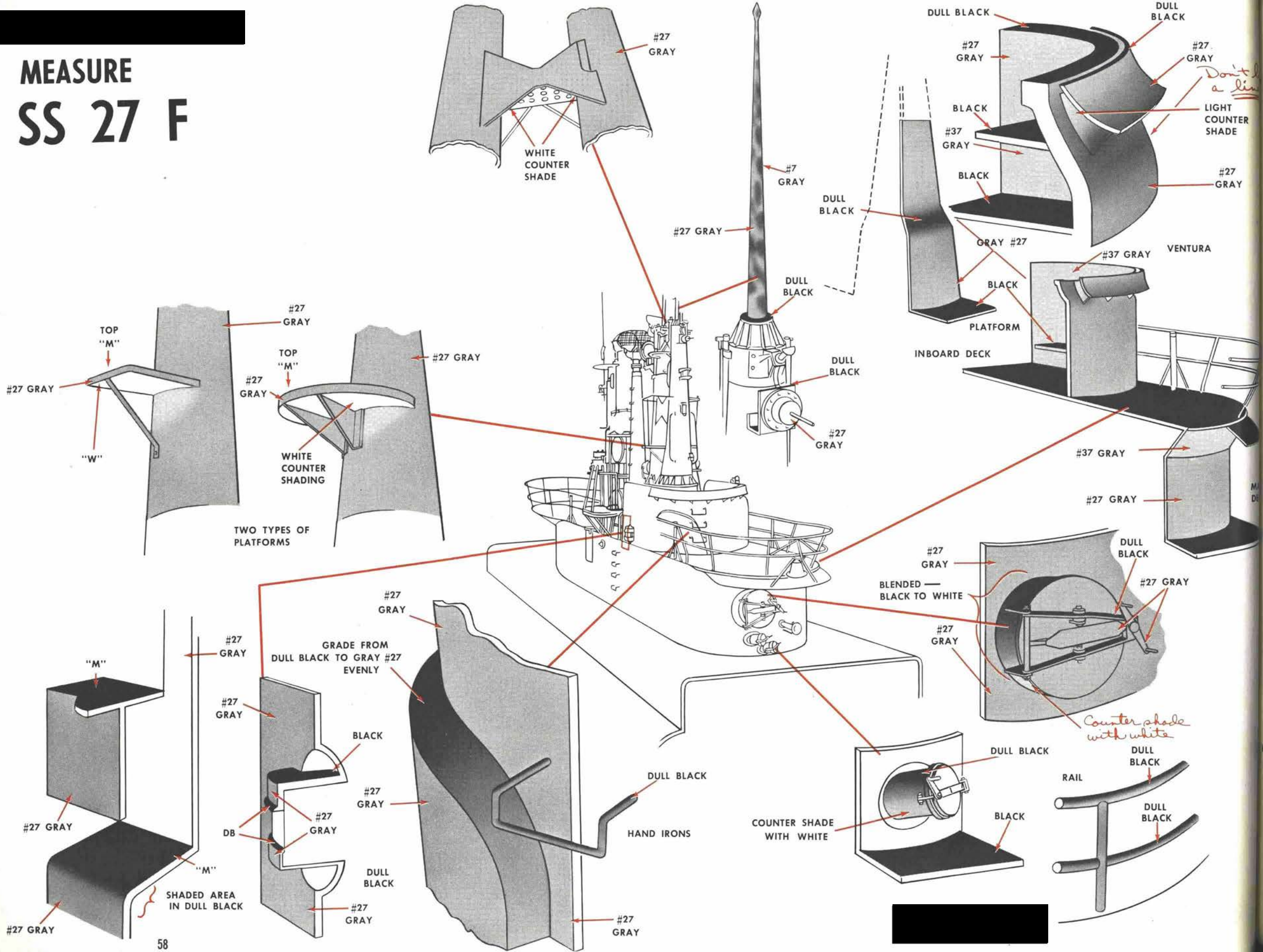

MEASURE SS 27 F

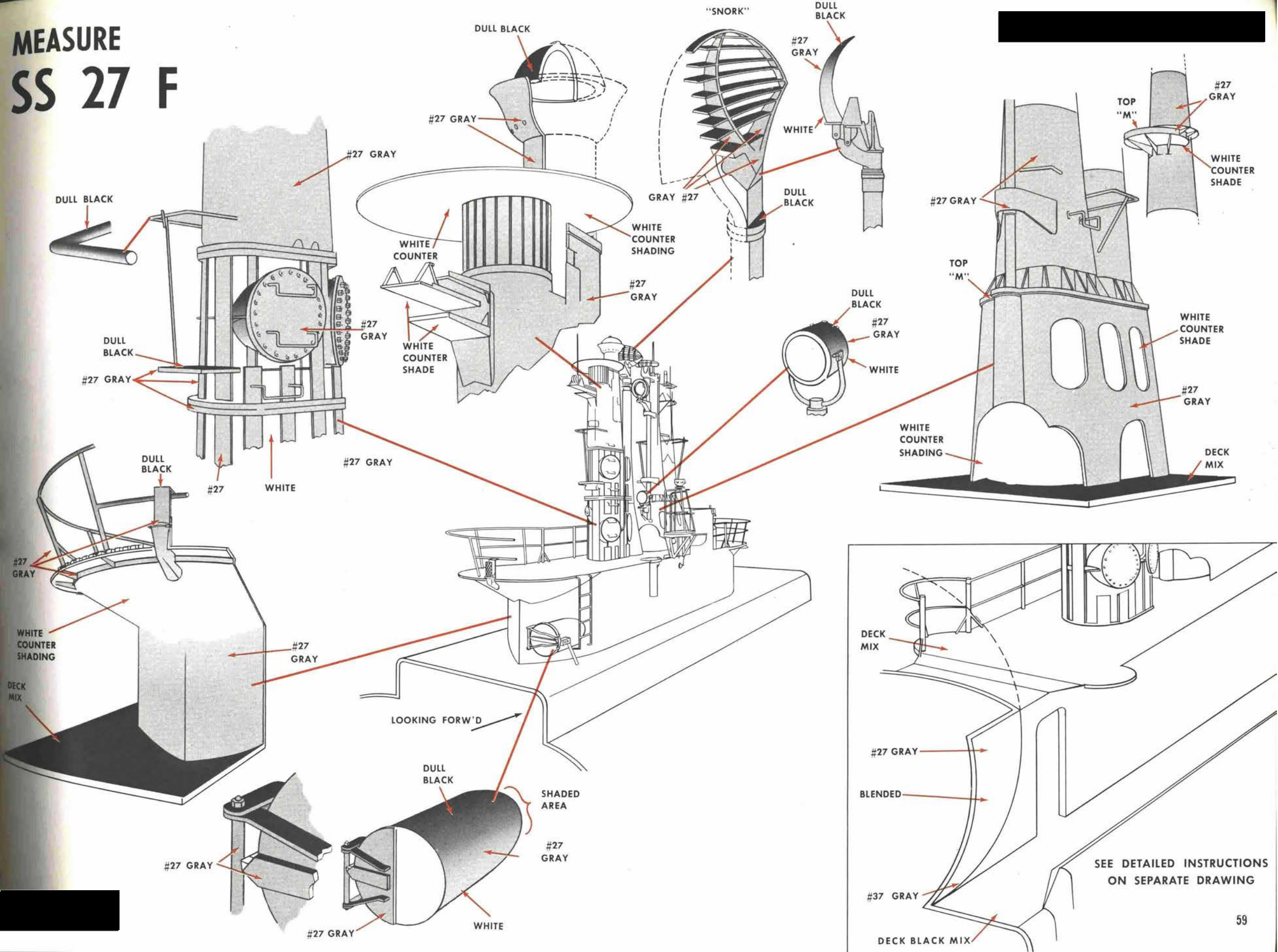

SEE DETAILED INSTRUCTIONS
ON SEPARATE DRAWING

MEASURE SS 27 F

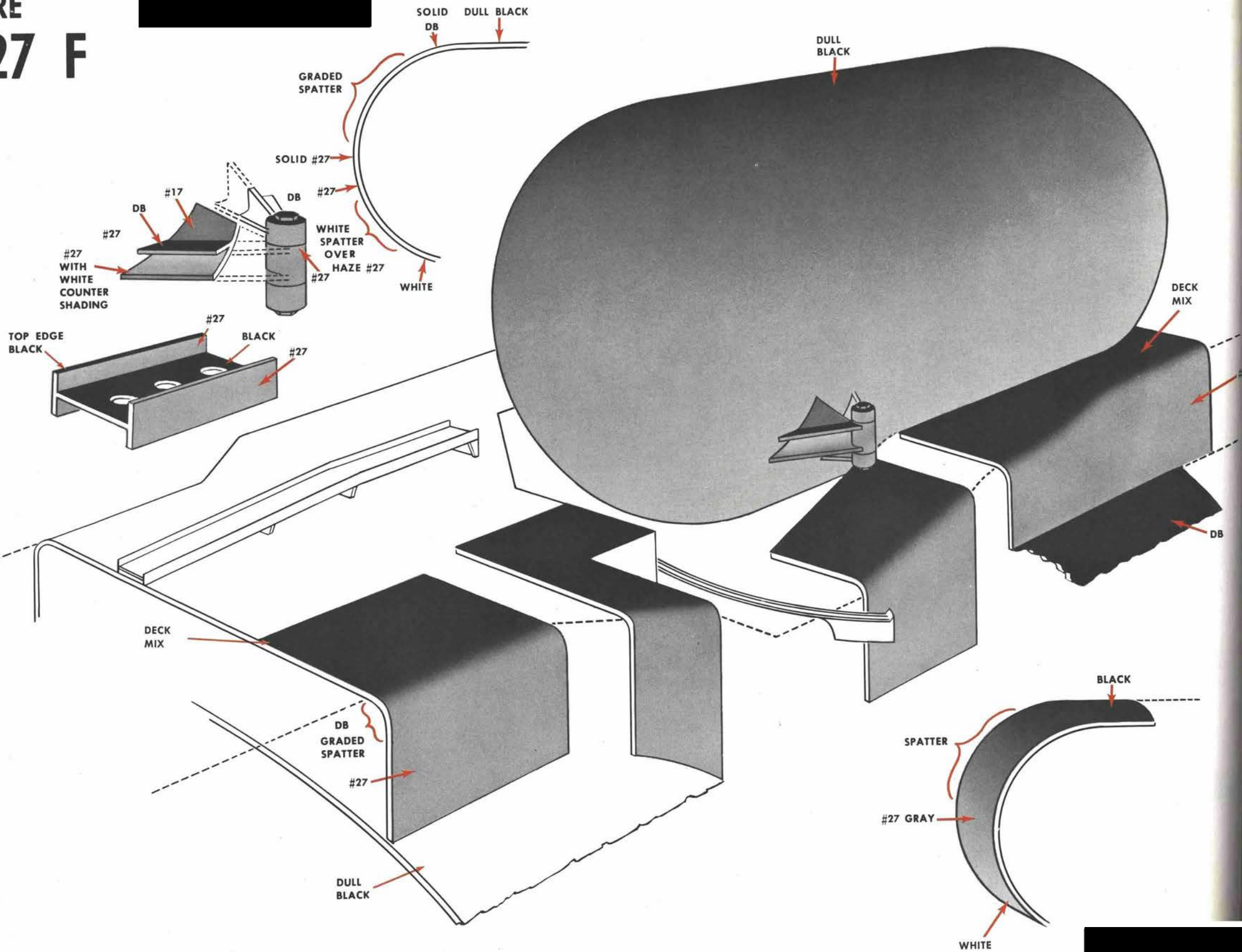

MEASURE SS 17 F

WITH DETAILS TO COVER CARGO, GUIDED MISSILE, AND TRANSPORT SUBMARINES

NOTE.—“How To Use A Spray Gun To Get Special Concealment Effects,” pages 20 to 27, shall be required reading for all painters before starting to paint this measure.

(A) *Word Description.* Ocean Gray (5-O), Stock No. G52-P-965, is the basic shade for this measure and shall be applied to the vertical sides from the pressure hull to the topmost part of the boat except as hereafter noted and shown on the illustrations for this measure.

Haze Gray (5-H), Stock No. G52-P-961, shall be applied to all of the vertical or nearly vertical surfaces that are inside of the bridge structure and to all surfaces 6 inches or more inside limber holes that can be reached by a painter stationed near the water line outside the boat, and to the top of the hull that is covered by the superstructure.

Haze Gray (5-H) shall also be used inside the bridge where white or deck black do not apply.

Haze Gray (5-H) shall be applied in solid coat to periscope necks and streamlined periscope fairings as the background shade for the dark spotting.

Navy Gray (5-N), Stock No. G52-P-963, shall be used for the dark spots on periscope necks and fairings. How to paint periscopes is described on page 24 and also illustrated.

Deck Paint Mixture shall be applied to all decks except on the rounded edges where Dull Black No. 104 is used as later described and illustrated.

Dull Black No. 104 shall be applied to all *rounded* surfaces facing generally upward including the rounded edges of decks, the upturned rounded surfaces of radar, the rounded top of sonar domes, all hand rails, the top of the pressure hulls, and tanks between the low water line and superstructure.

Dull Black No. 104 may also be used for making the spatter gradations from dull black areas to lighter areas as illustrated for this measure.

White No. 6, Stock No. G52-P-5305, shall be applied in solid coat to the overhead and to all other areas of the bridge except those portions which may become exposed to the direct rays of the sun.

White No. 6 shall be applied to the interior of the superstructure above the hull and below the main deck (forward of the conning tower) including the under side of the main deck and the interior of the sides. Aft of the conning tower, inside the superstructure, is unimportant. White shall *not* be applied to the top of the hull, even beneath the main deck.

Snorkel exhaust baffle plates (where applicable): The *top* of these plates, that is, the horizontal surface which faces upward, shall be painted by *brush* with Dull Black No. 104, Stock No. G52-P-5075. The *under* side of these plates shall be painted by *brush* with Pure White, Stock No. G52-P-5305.

Details of radar picket boats shall be painted as shown in illustrations. Hangars and other details as applicable to cargo, guided missile, and transport submarines shall be painted as

shown on illustrations by techniques described in section 3b.

(B) Effectiveness and Suitability. This is a modification of the dark measure (formerly listed in NavShips 250-631 as No. 32/9SS). It is applicable to Fleet-type submarines.

This measure is appreciably less effective than SS 27 F for night surface operations but more effective for submerged operations and for most daylight surface operations.

Surfaced or submerged, submarines painted with this measure are very difficult to detect against a sea background when approached by aircraft flying away from the sun. Distant aircraft or aircraft which are low have less chance of detecting the wake than do aircraft at high altitude because of the small downward angle. Surfaced submarines painted with this measure blend well with their background when approached from their sunlit side; aircraft flying below 5,000 feet and "out of the sun" must generally approach to within 6 or 8 miles before sighting either surfaced submarine or wake under good or average daylight conditions. However, when approached from the shaded side, these submarines will be darker than the sea background on both clear and cloudy days whether the submarine is submerged or surfaced. This contrast of the dark boat against the brighter sea or sky background is more pronounced on cloudy days than on clear days; is most pronounced on cloudy days when the sea is calm. This follows because on overcast days the smoother the sea the brighter it appears from all oblique angles.

MEASURE SS 17 F

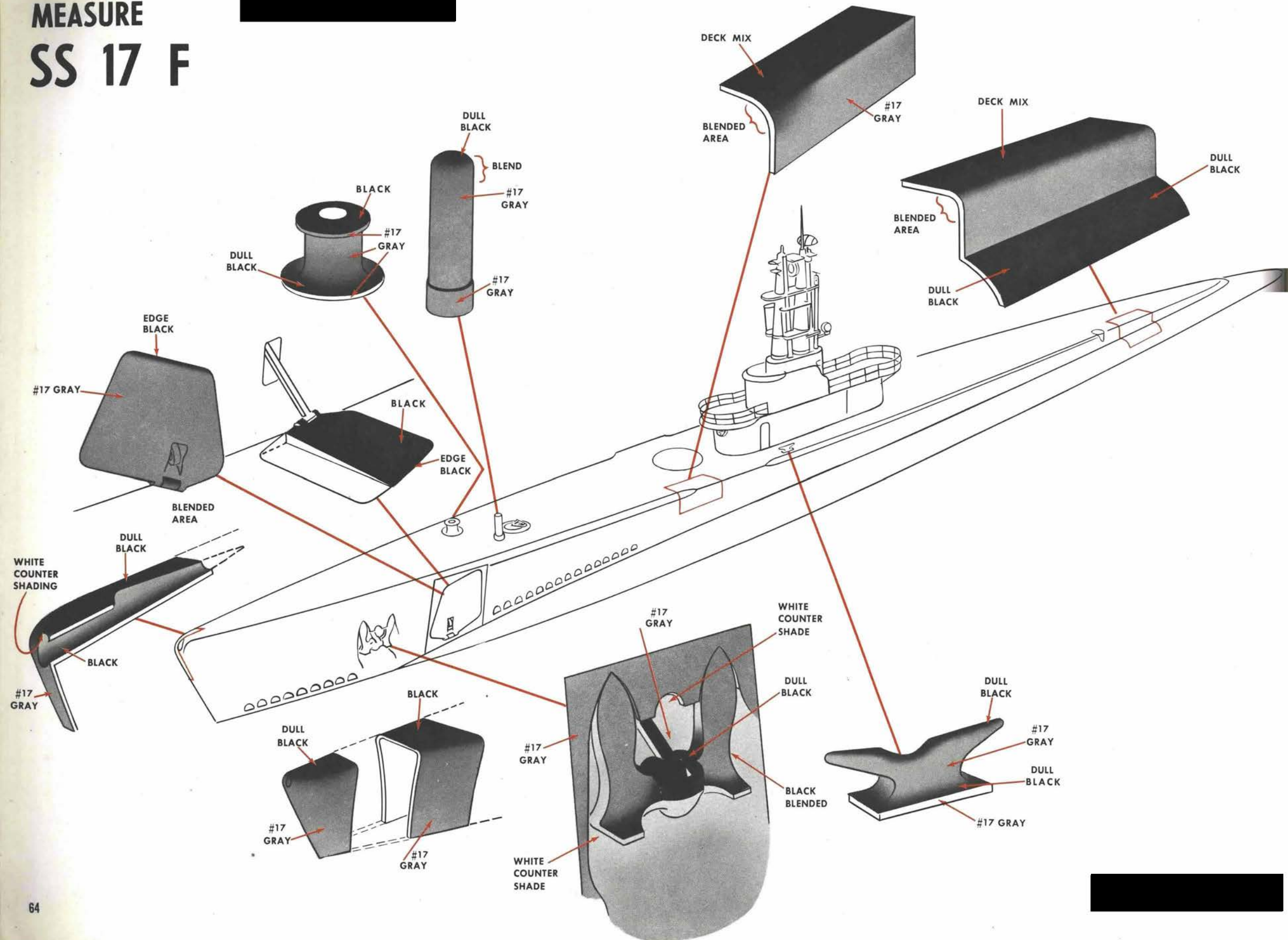

MEASURE SS 17 F

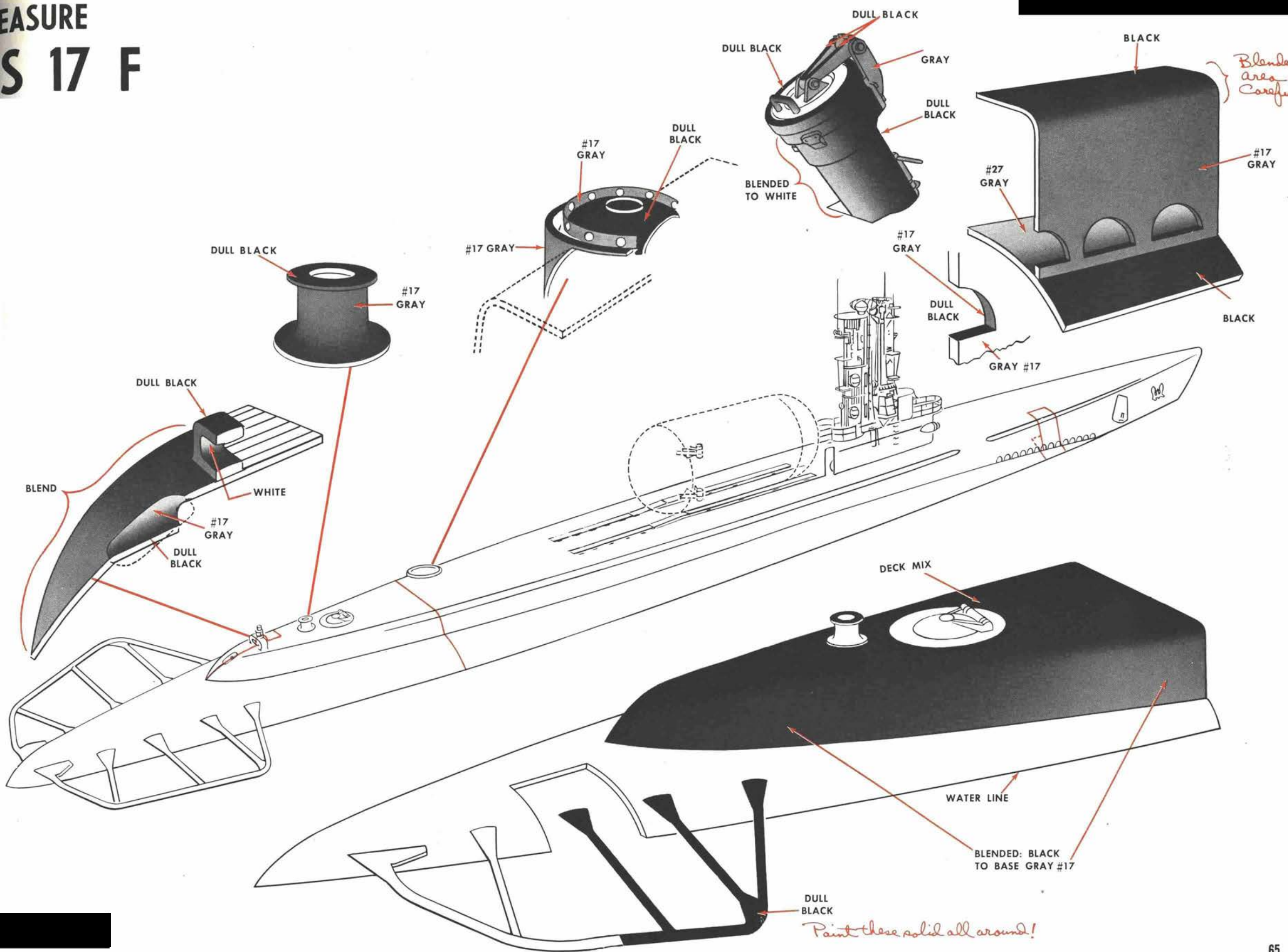

MEASURE SS 17 F

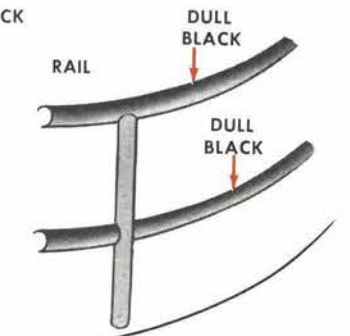
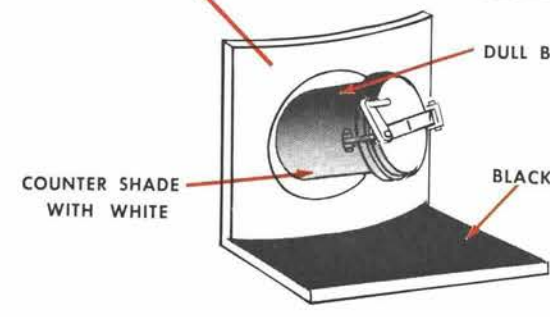
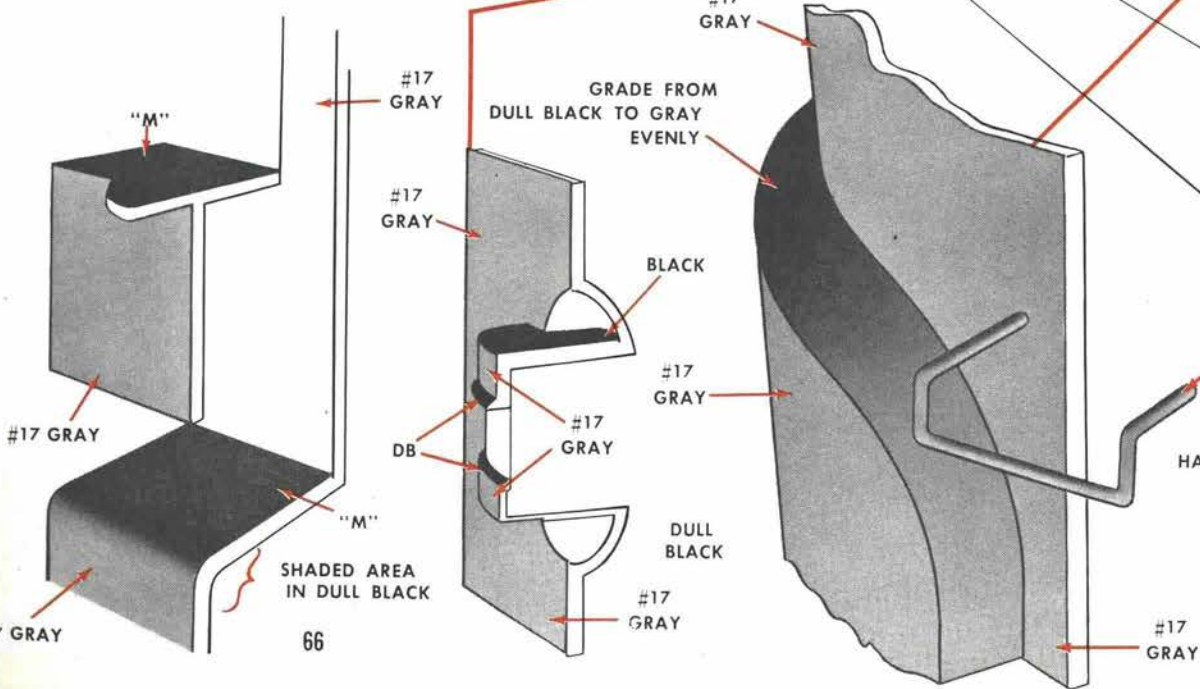
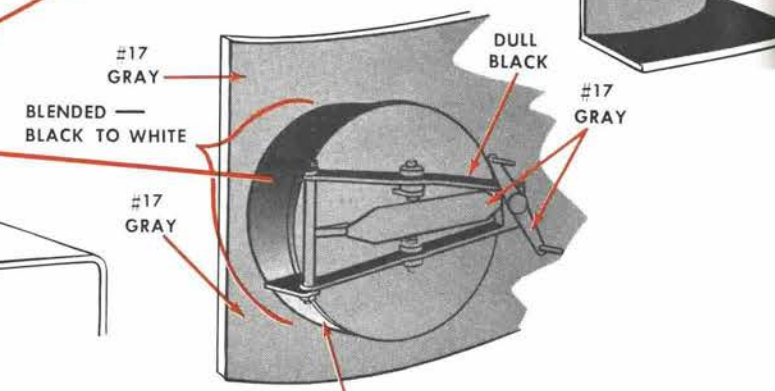
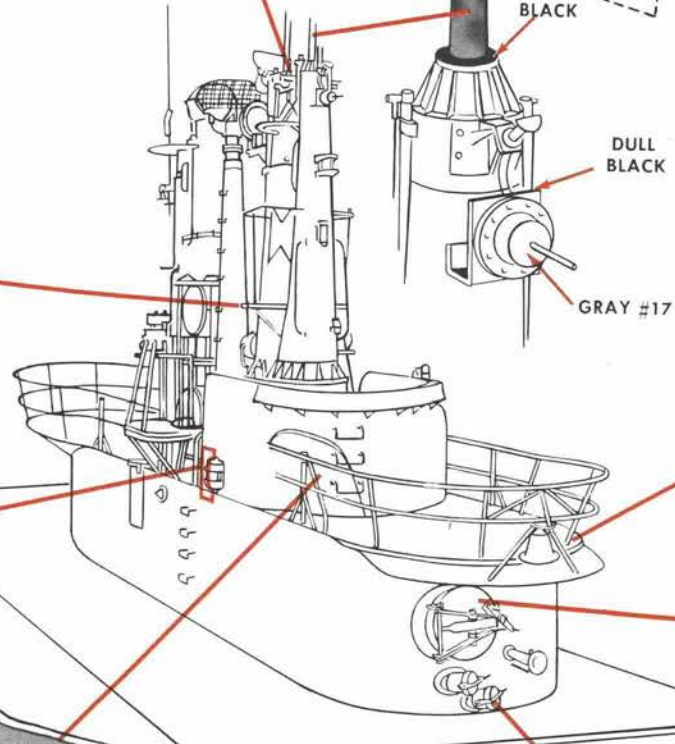
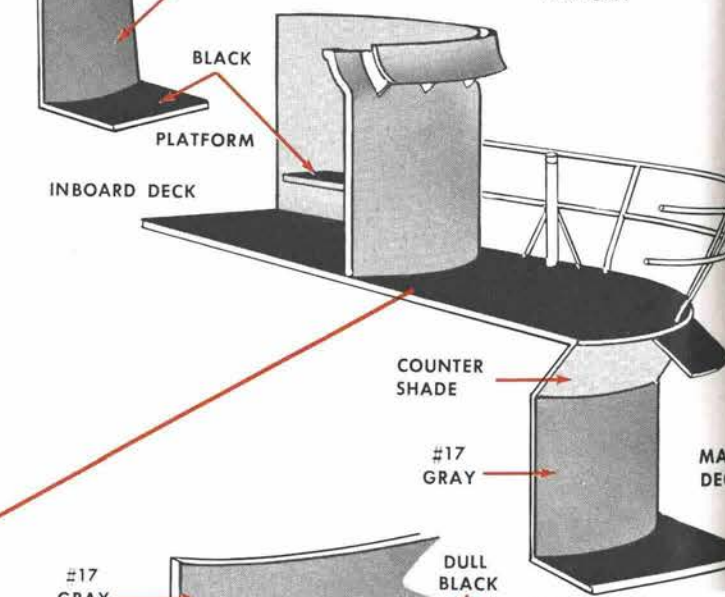
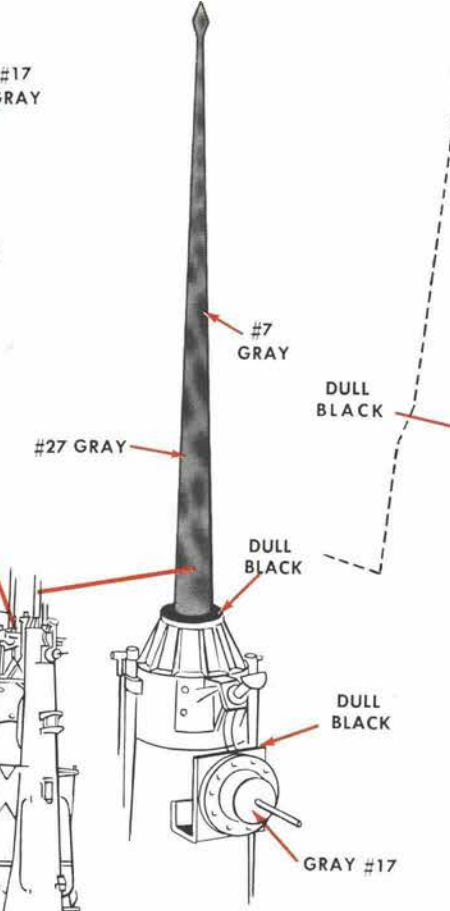
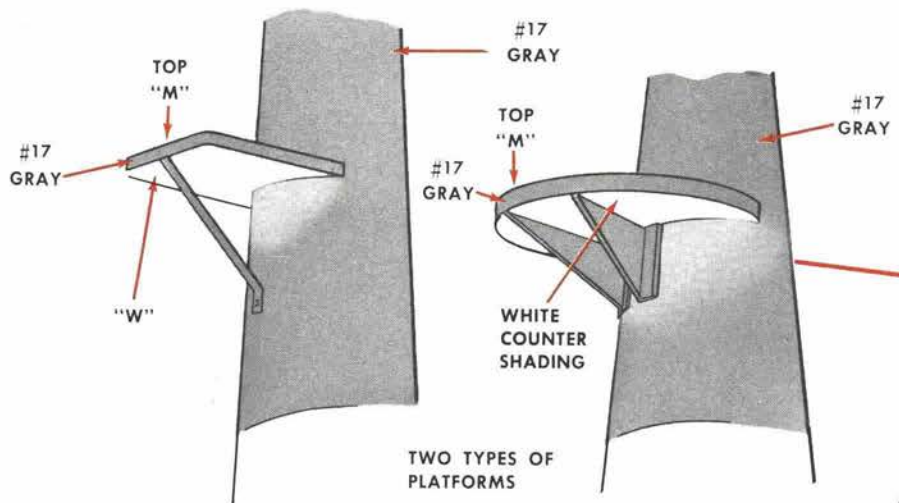
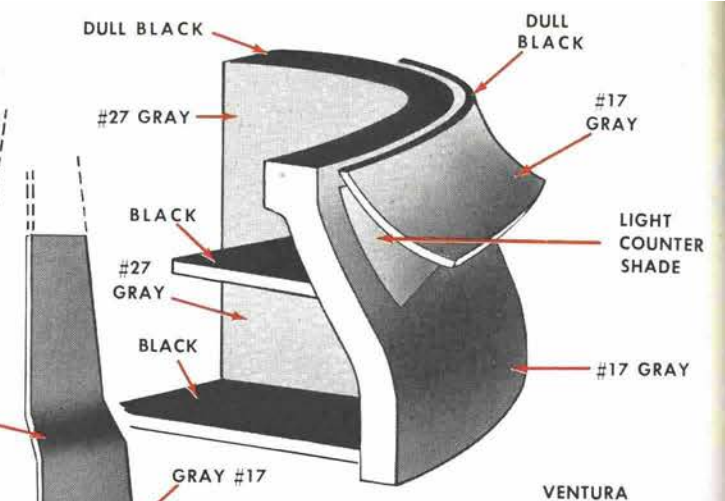
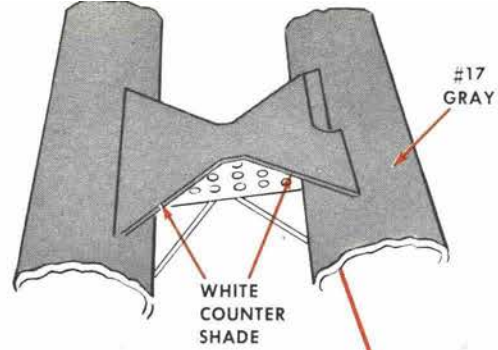

MEASURE SS 17 F

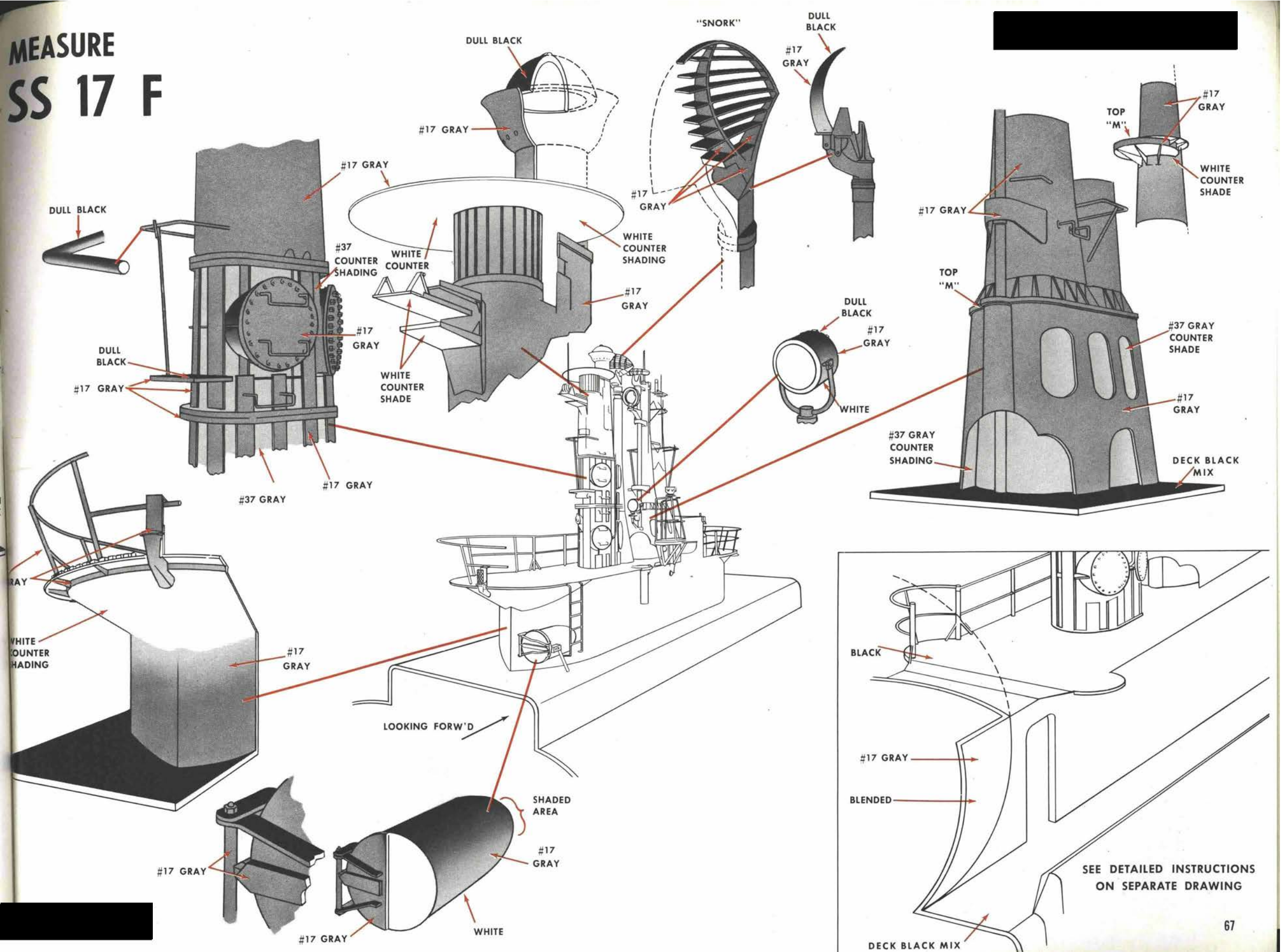

DULL BLACK

DULL BLACK

#17 GRAY

WHITE COUNTER SHADING

#17 GRAY

#17 GRAY

#17 GRAY

#17 GRAY

LOOKING FORW'D

SHADED AREA

#17 GRAY

WHITE

DULL BLACK

#17 GRAY

#17 GRAY

#37 COUNTER SHADING

WHITE COUNTER

#17 GRAY

WHITE COUNTER SHADE

#37 GRAY

#17 GRAY

"SNORK"

DULL BLACK

#17 GRAY

#17 GRAY

WHITE COUNTER SHADING

#17 GRAY

DULL BLACK

#17 GRAY

WHITE

#37 GRAY COUNTER SHADING

DECK BLACK MIX

#17 GRAY

TOP "M"

#37 GRAY COUNTER SHADE

#17 GRAY

TOP "M"

#17 GRAY

WHITE COUNTER SHADE

BLACK

#17 GRAY

BLENDED

DECK BLACK MIX

SEE DETAILED INSTRUCTIONS ON SEPARATE DRAWING

MEASURE SS 17 F

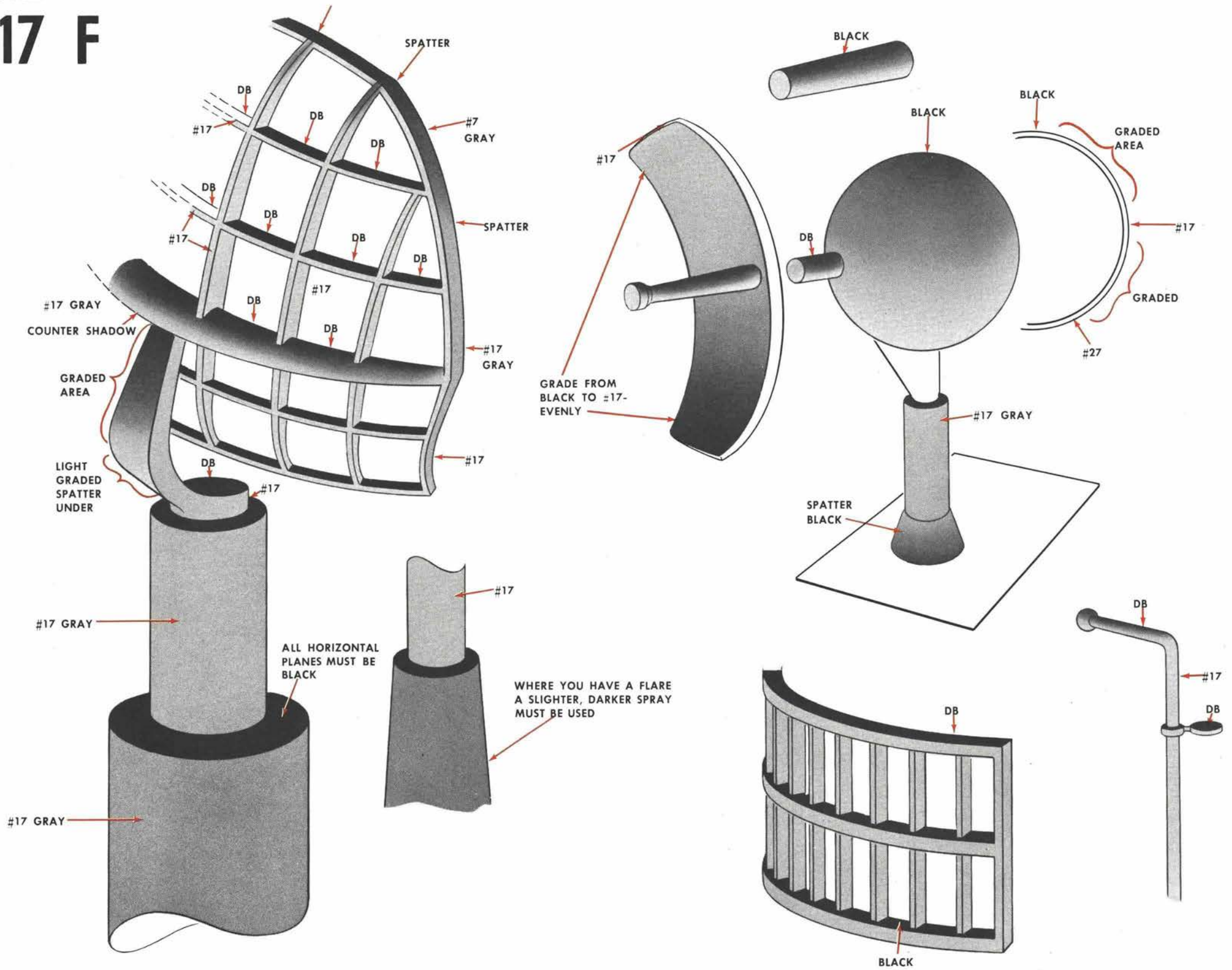



MEASURE SS 11 F

NOTE.—"How To Use a Spray Gun To Get Special Submarine Concealment Effects," pages 20 to 27, shall be required reading for all painters before starting to paint this measure.

(A) Word description. Outside Gray No. 11, Stock No. G52-P-5086-5, is the basic shade for this measure and shall be applied to the vertical sides from the pressure hull to the topmost part of the boat except as hereafter noted and shown on the illustrations for this measure.

Haze Gray (5-H), Stock No. G52-P-961, shall be applied to all of the vertical or nearly vertical surfaces that are inside of the bridge structure and to all surfaces six inches or more inside limber holes that can be reached by a painter stationed near the water line outside the boat, and to the top of the hull that is covered by the superstructure.

Haze Gray (5-H) shall also be used inside the bridge where white or deck black do not apply.

Haze Gray (5-H) shall be applied in solid coat to periscope necks and streamlined periscope fairings as the background shade for the dark spotting.

Navy Gray (5-N), Stock No. G52-P-963, shall be used for the dark spots on periscope necks and fairings. How to paint a periscope is described on page 24 and also illustrated.

Deck Paint Mixture shall be applied to all decks except on the rounded edges where dull black No. 104 is used as later described and illustrated.

Dull Black No. 104 shall be applied to all rounded surfaces facing generally upward including the rounded edges of decks, the upturned rounded surfaces of radar, the rounded top of sonar domes, all hand rails, the top of the pressure hulls, and tanks between low water line and superstructure.

Dull Black No. 104 may also be used for making the spatter gradations from dull black areas to lighter areas as illustrated for this measure.

White No. 6, Stock No. G52-P-5305, shall be applied in solid coat to the overhead and to all other areas of the bridge except those portions which may become exposed to the direct rays of the sun.

White No. 6 shall be applied to the interior of the superstructure above the hull and below the main deck (forward of the conning tower) including the under side of the main deck and the interior of the sides. Aft of the conning tower, inside the superstructure, is unimportant. White shall not be applied to the top of the hull, even beneath the main deck.

(B) Effectiveness and Suitability. This measure provides

considerably more concealment for a fully submerged boat than measures SS 27 F or SS 17 F when viewed away from the sun, but a little less concealment when viewed from the opposite direction. In the latter case the forward scattering of light in the water silhouettes the submarine as a dark object against the brighter background. Since in most circumstances there is the deterring factor of glare from the water's surface when looking toward the sun, the net gain is appreciable for submerged operation. On the other hand, this measure is more readily detectable at a distance on the surface or close aboard from small downward angles of view than any of the other measures previously mentioned in this paragraph which are all appreciably lighter. This is especially true on overcast days when the surface of the sea viewed from a grazing angle appears much brighter in most directions than it appears on sunny days. Under average sea and sunlight conditions and downward at angles of 35° or more, the wake of a surfaced submarine is more readily detectable to aviators looking away from the sun than the submarine itself provided any one of the submarine concealment measures short of white is used. Hence, nothing is gained by this darker measure from the point of view just described. The gain is for submerged operations.

MEASURE SS 11 F

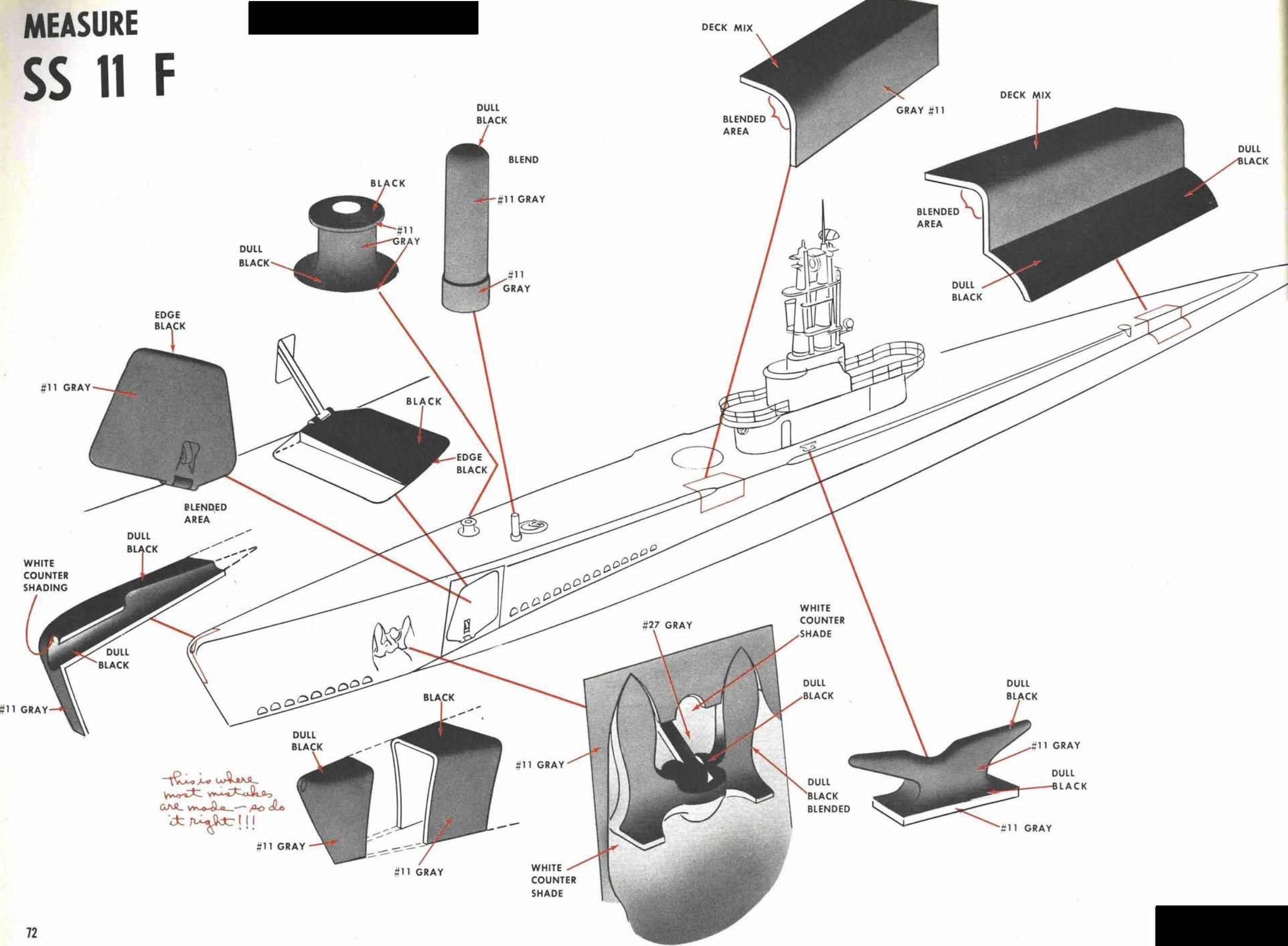

MEASURE SS 11 F

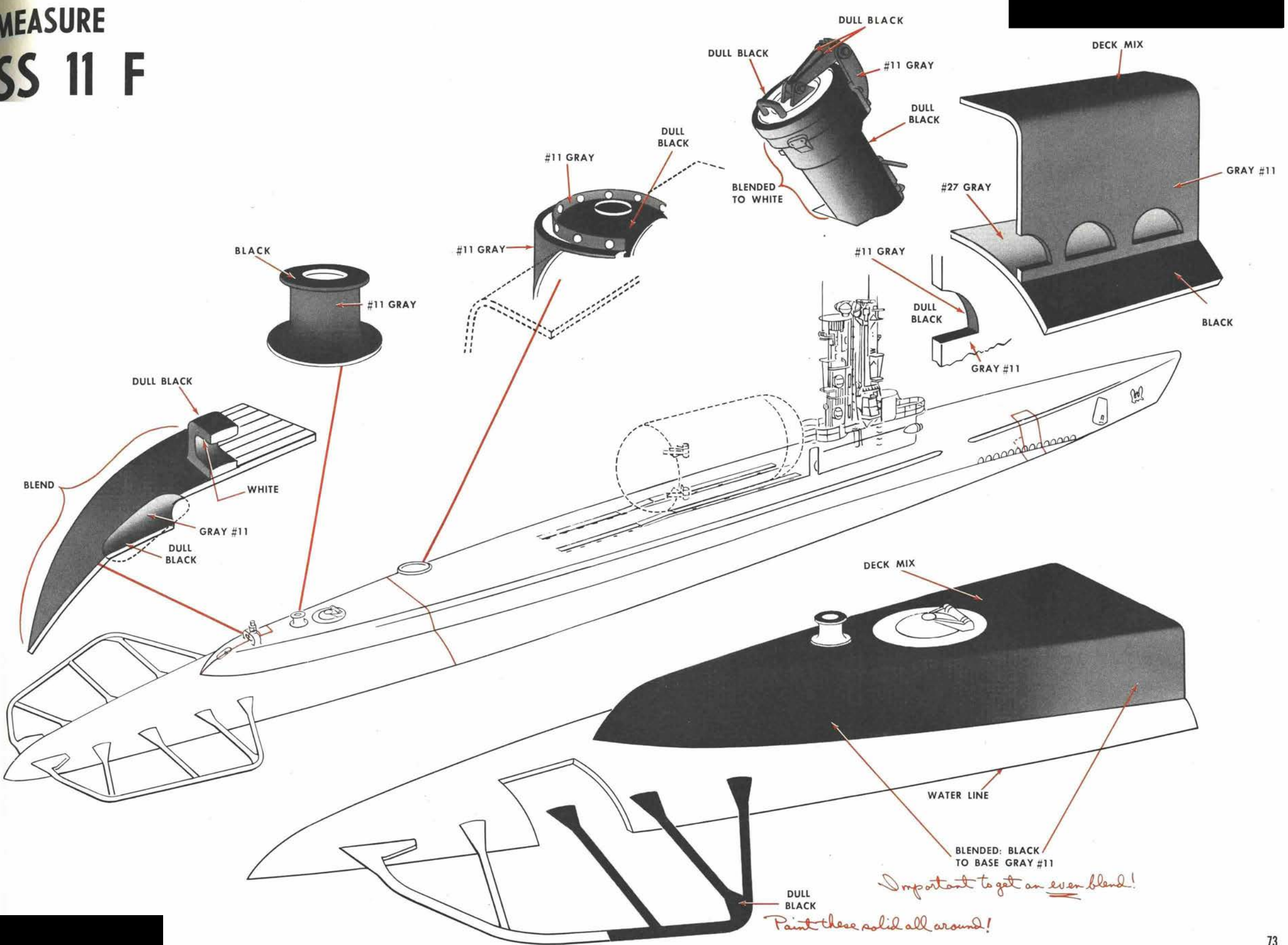

MEASURE SS 11 F

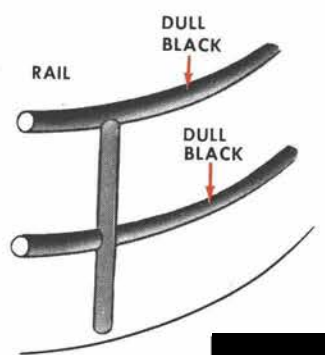
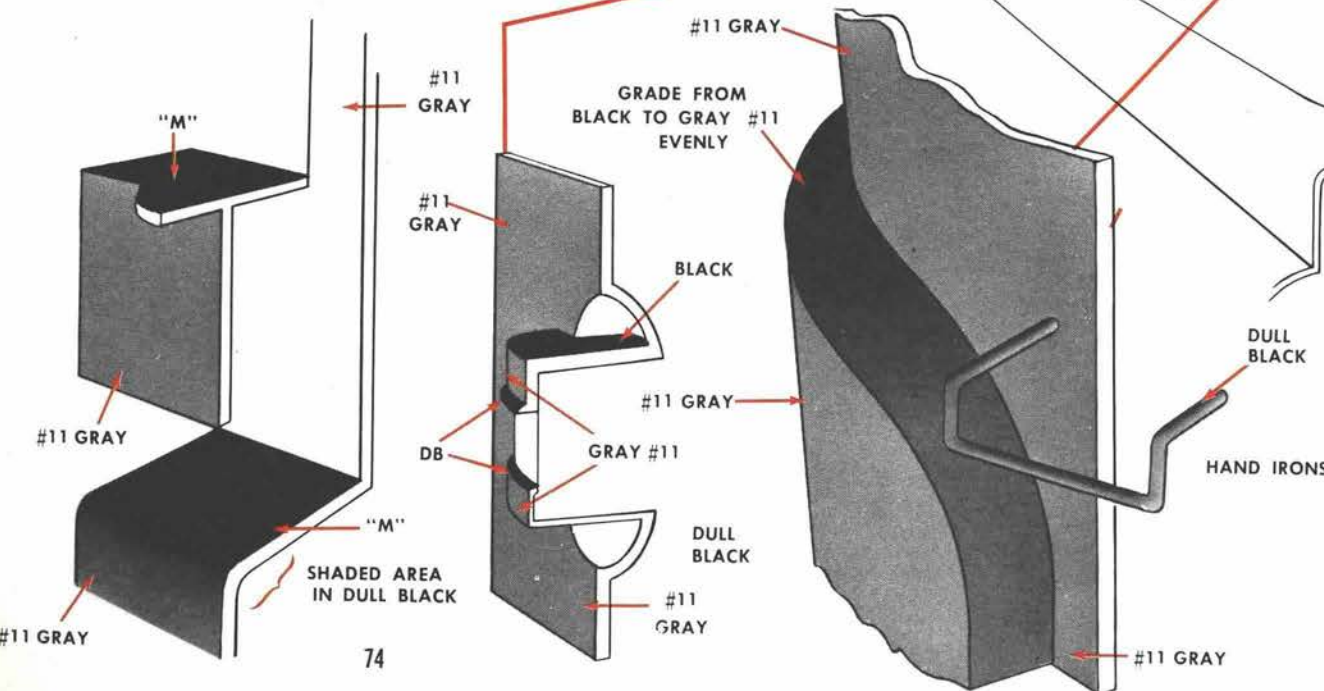
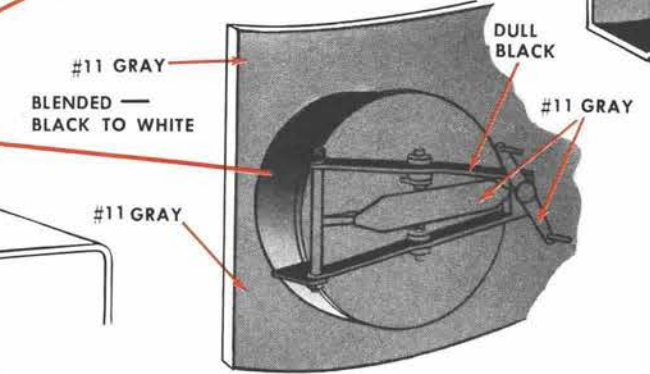
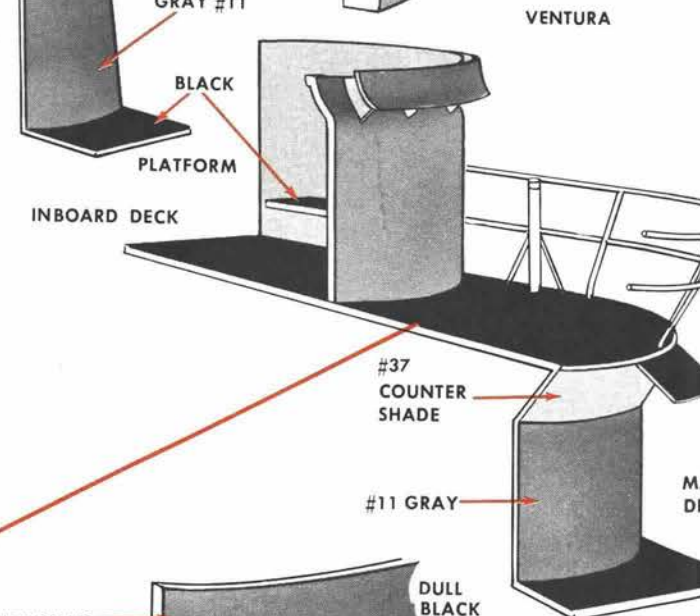
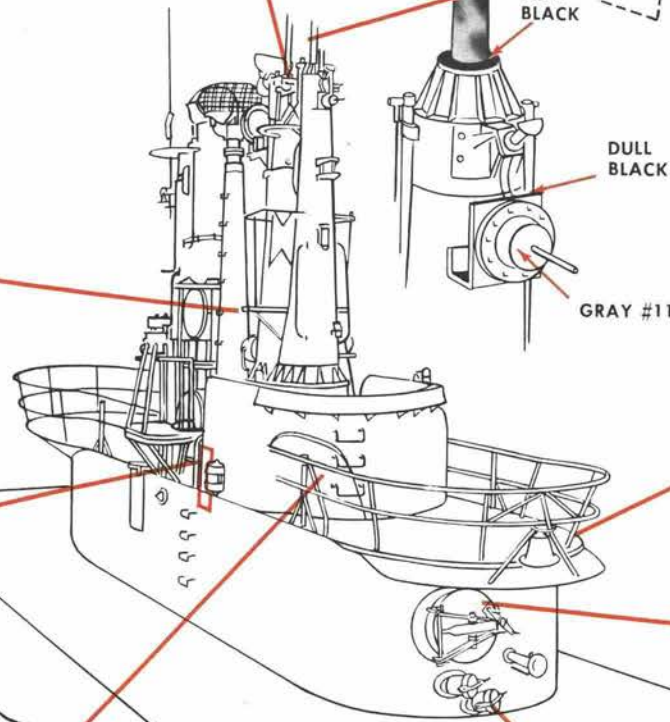
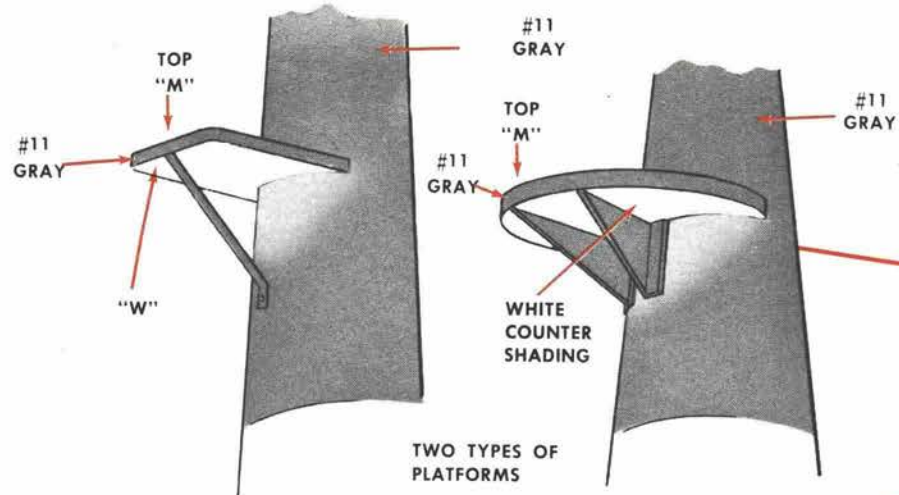
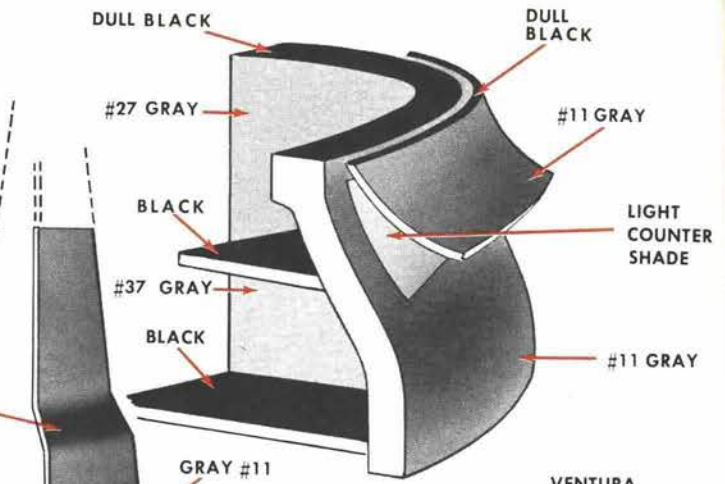
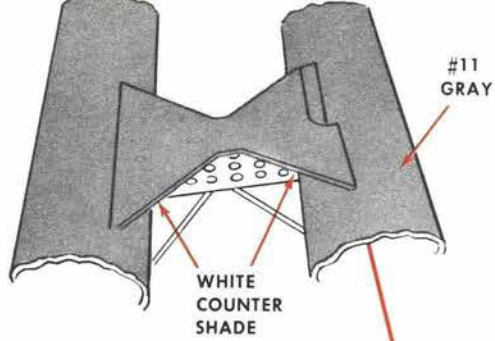

MEASURE SS 11 F

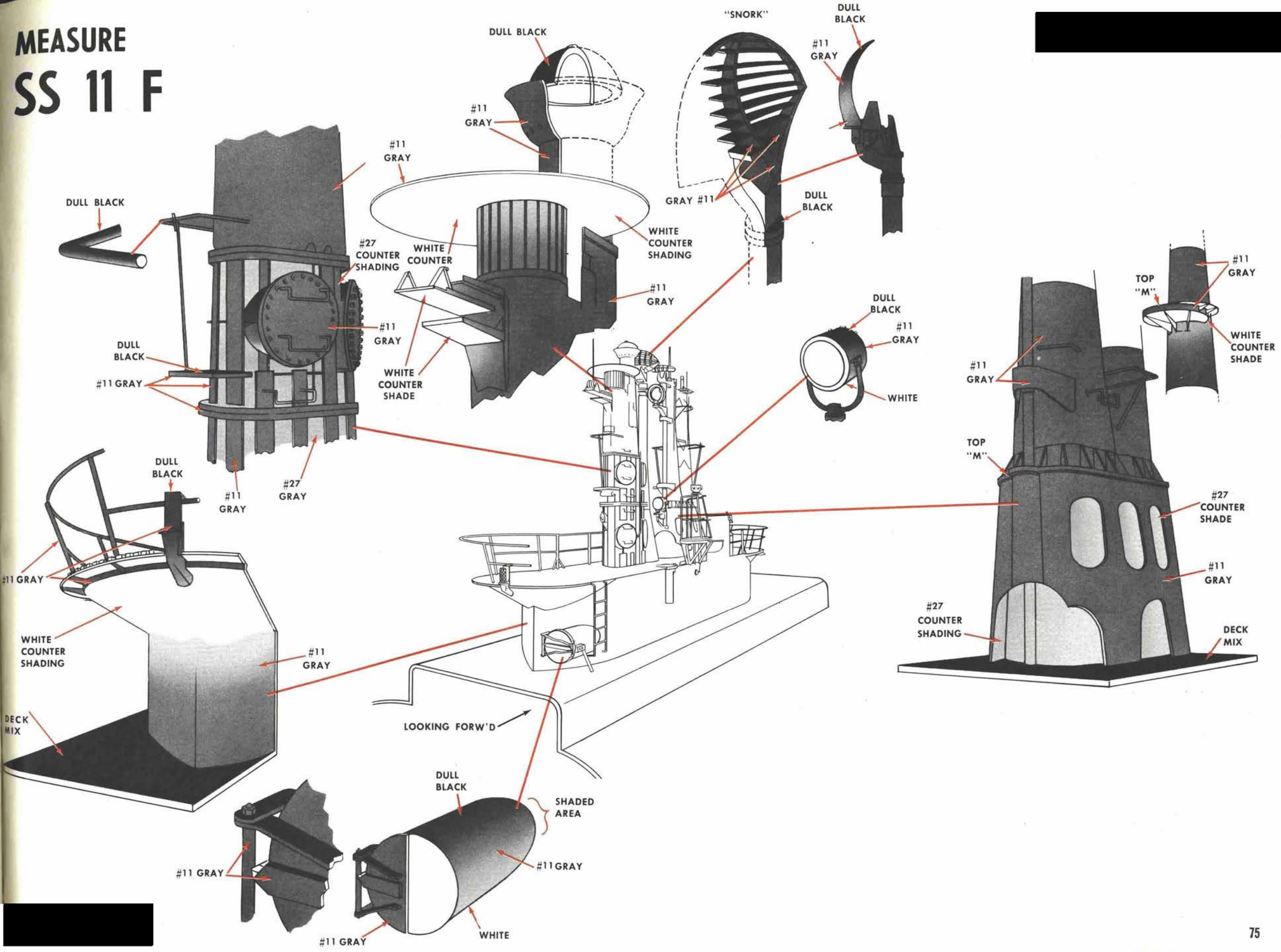

MEASURE SS 7 F

NOTE.—"How to Use a Spray Gun to Get Special Submarine Concealment Effects," pages 20 to 27, shall be required reading for all painters before starting to paint this measure.

(A) Word Description. Navy Gray (5-N), Stock No. G52-P-963, is the basic shade for this measure and shall be applied to the vertical sides from the pressure hull to the topmost part of the boat except as hereafter noted and shown on the illustrations for this measure.

Ocean Gray (5-O), Stock No. G52-P-965, shall be applied to all of the vertical or nearly vertical surfaces that are inside of the bridge structure and to all surfaces 6 inches or more inside limber holes that can be reached by a painter stationed near the water line outside the boat, and to the top of the hull that is covered by the superstructure.

Ocean Gray (5-O) shall also be used inside the bridge where white or deck black do not apply.

Haze Gray (5-H) shall be applied in solid coat to periscope necks and streamlined periscope fairings as the background shade for the dark spotting.

Navy Gray (5-N), Stock No. G52-P-963, shall be used for the dark spots on periscope necks and fairings. How to paint periscopes is described on page 24 and also illustrated.

Deck Paint Mixture shall be applied to all decks except on the rounded edges where Dull Black No. 104 is used as later described and illustrated.

Dull Black No. 104 shall be applied to all *rounded* surfaces facing generally upward including the rounded edges of decks, the upturned rounded surfaces of radar, the rounded top of sonar domes, top of snorkel, all hand rails, the top of the pressure hulls, and tanks between the low water line and superstructure.

Dull Black No. 104 may also be used for making the spatter gradations from dull black areas to lighter areas as illustrated for this measure.

Haze Gray (5-H) Stock No. G52-P-961, shall be applied in solid coat to the overhead and to all other areas of the bridge except those portions which may become exposed to the direct rays of the sun.

Snorkel exhaust baffle plates: The top of these plates, that is, the horizontal surface which faces upward, shall be painted by *brush* with dull black No. 104, Stock No. G52-P-5075. The *under* side of these plates shall be painted by *brush* with pure white, Stock No. G52-P-5305.

(B) Effectiveness and Suitability. This is another, and possibly the best, all-out submerged measure, although the superior effectiveness of this measure over SS 11 G has not been clearly established. *However, it is believed to be superior to any other measure in the one condition under which submarines have been followed to maximum depth, namely, under the most favorable*

conditions for sighting, which includes smooth sea, sun's altitude between 50° and 70°, clear deep water, and with the observer looking steeply downward (50° to 70°) with the sun behind the observer. Under the conditions described, submarines painted with this measure are harder to see than with any other painting known, and are lost to view generally around 75 feet keel depth or before. Looking toward the sun this does not hold. This measure is too dark and stands out in silhouette and, of course, *it is much too dark for any surface operation.*

Under very moderate sea, no white caps and variously described as state one and one plus, but with other conditions as described above, neither the writer nor his pilot was able to sight a boat so painted after it was seen to go completely under. This was repeated on several occasions.

Again attention is invited to the fact that boats painted with 17 or 11 percent reflectant paints on their sides as in SS 17 G and SS 11 G, respectively, are very hard to see submerged also, and almost never are sighted, except under ideal sighting conditions. Since this measure goes to such an extreme to achieve maximum concealment submerged against the one worst condition, it appears doubtful that its adoption for general use is the best policy, for the gain cannot be had without additional risk to the boat on the surface where it is much more likely to be sighted either at night, twilight, or in the daytime.

MEASURE SS 7 F

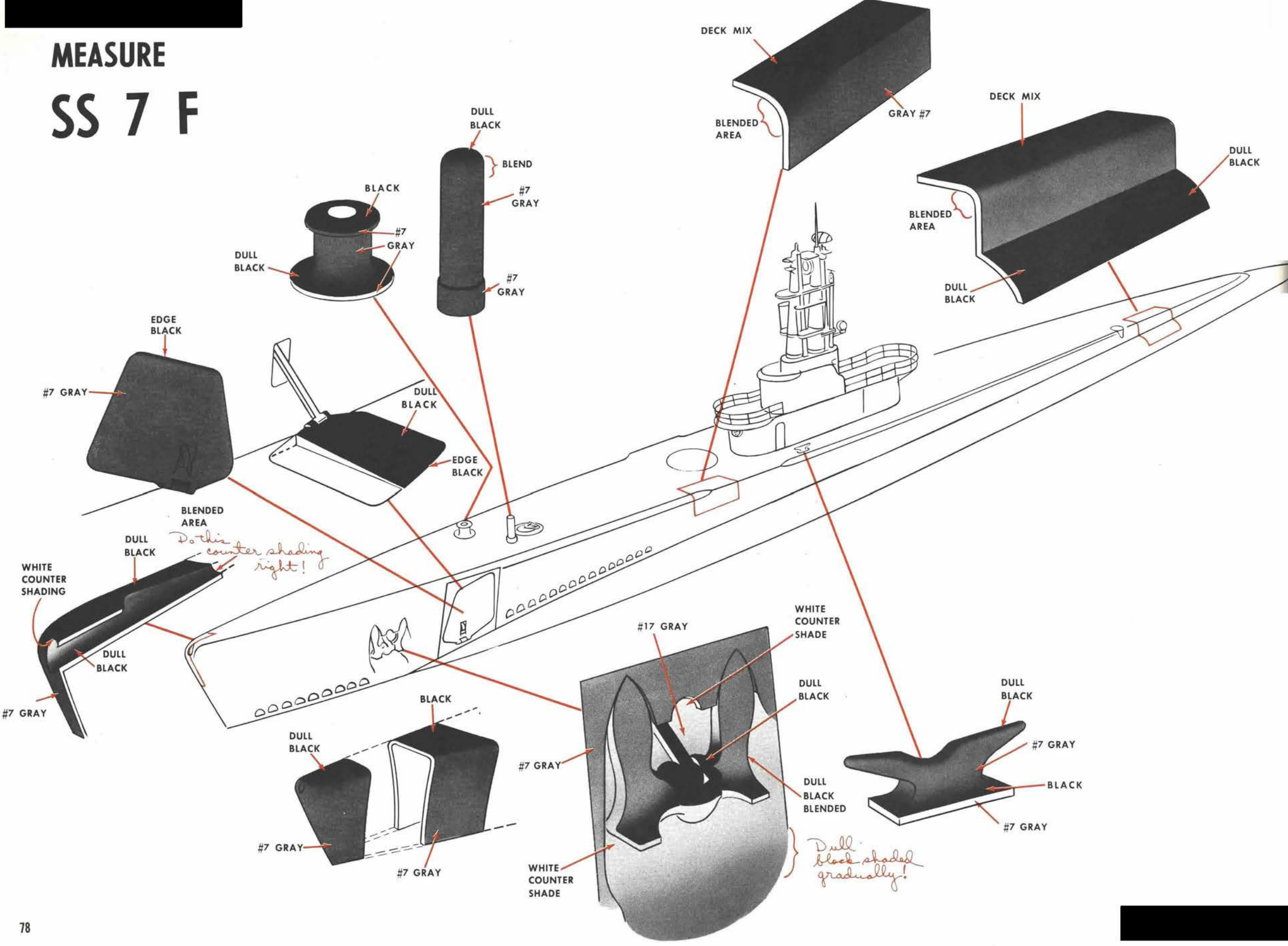

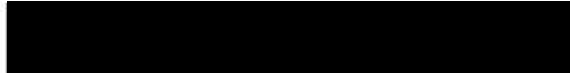

MEASURE SS 7 F

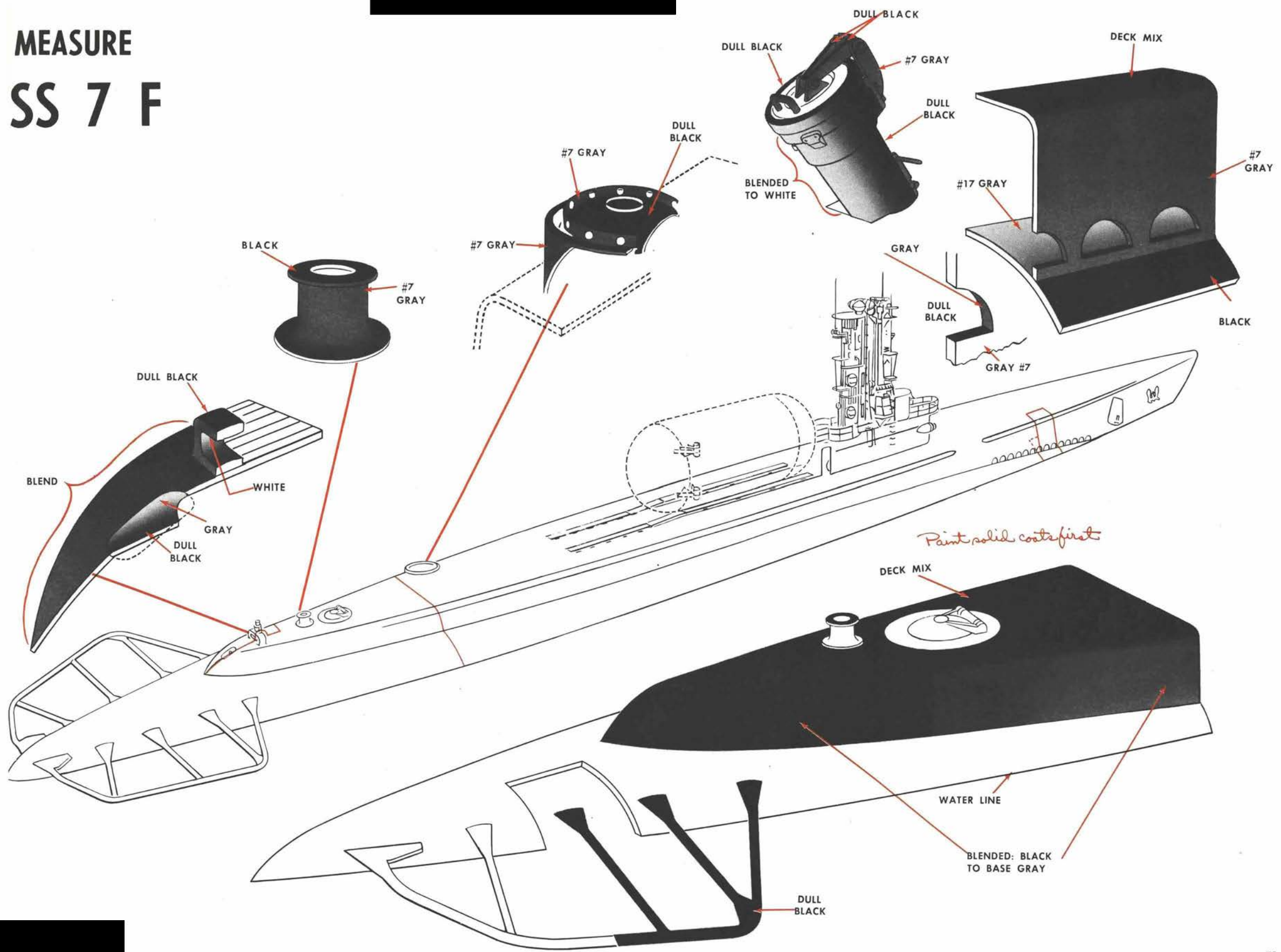

MEASURE SS 7 F

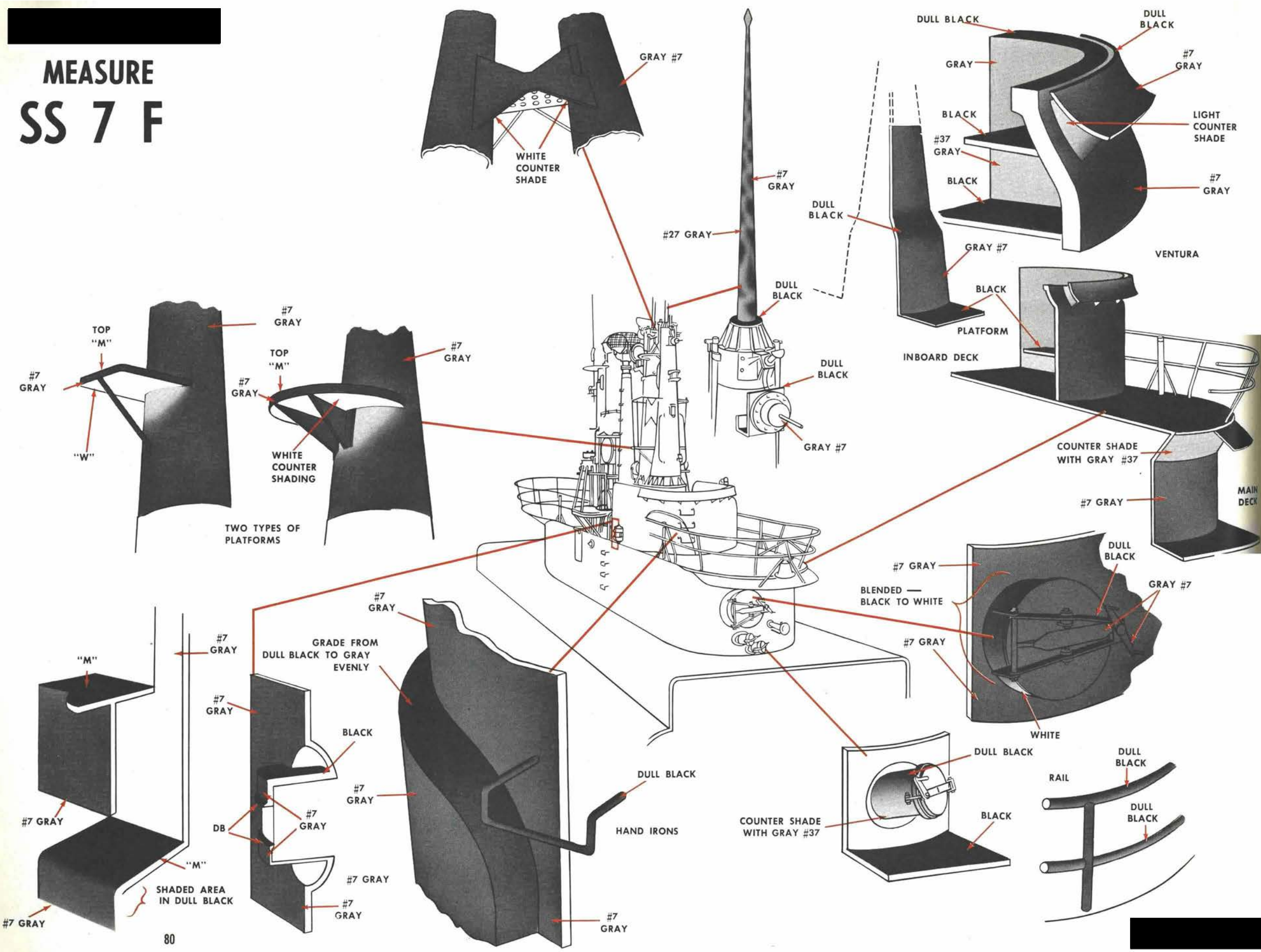

MEASURE SS 7 F

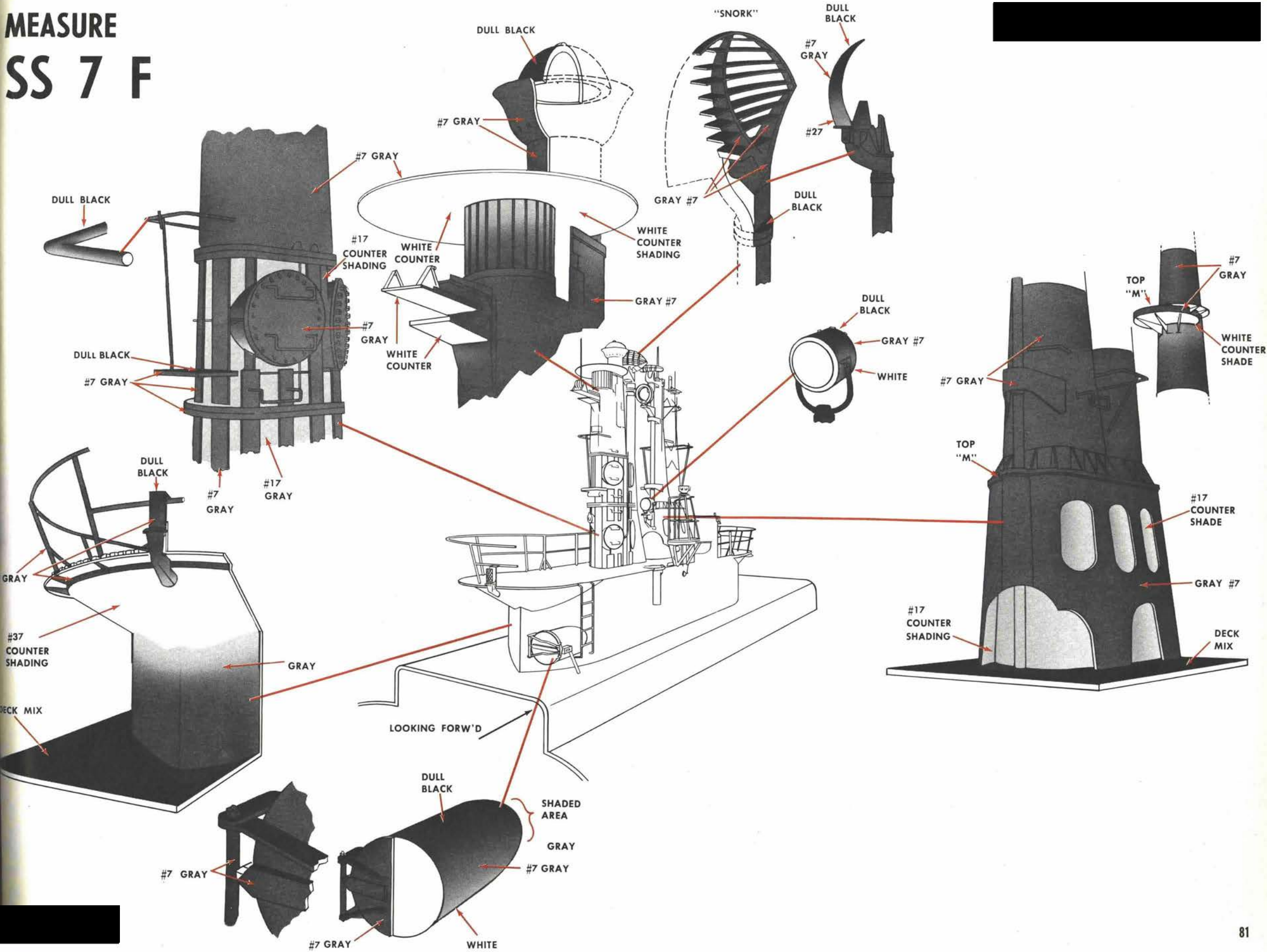

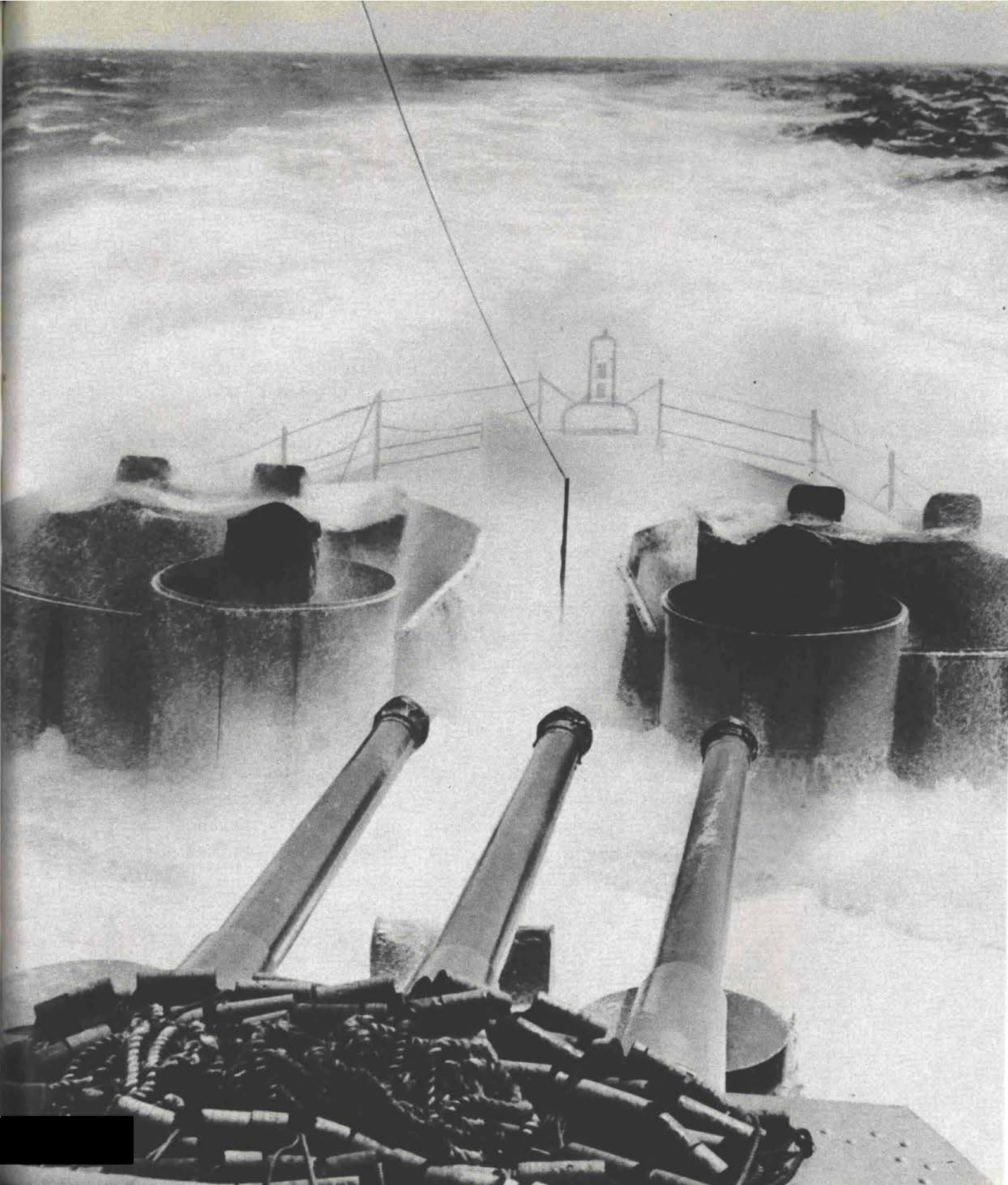

SUBMARINE PAINTS AND PAINTING EQUIPMENT

SECTION 4

SUBMARINE PAINTS AND PAINTING EQUIPMENT

Navy outside paints are all theoretically neutral grays made from white and black in various proportions. Actually they are slightly bluish due to the slight influence of blue in the white paint.

There are a number of these gray paints used in concealment measures. All are ready-mixed at the paint factories to the proper shade of gray and to the proper consistency for adhesion, wear, and coverage. A sufficient number of shades between black and white have been provided for convenience and to avoid the necessity for mixing in the Fleet. However, occasional shades may not be readily procurable at some advance base and it may therefore be necessary to mix up some particular shade. This can be done by taking outside dull white, formula 5-U Stock No. G-52-P-5335, and adding a sufficient amount of Dull Black No. 104 Stock No. G52-P-5075, to obtain the required shade, or two of the grays can be mixed together to obtain an intermediate shade. The various shades of gray are conveniently designated by the relative amount of light each reflects. It so happens that the various shades chosen come in the sequences lightest to darkest with the approximate reflectances as follows:

| | <i>Approximate reflectance (percent)</i> |
|------------------------|--------------------------------------------------|
| White..... | 80 |
| Pale Gray No. 47..... | 47 |
| Light Gray No. 37..... | 37 |
| Haze Gray No. 27..... | 27 |

| | <i>Approximate reflectance (percent)</i> |
|--------------------------|--------------------------------------------------|
| Ocean Gray No. 17..... | 17 |
| Outside Gray No. 11..... | 11 |
| Navy Gray No. 7..... | 7 |
| Black No. 104..... | 3½ |

These are the reflectances in air. The reflectance of these same paints under water is different and must be measured under water.

Both wet and dry samples of each of the shades listed above should be kept on hand in every Navy paint shop or locker. Small glass jars or half-pint cans of wet samples are necessary to mix a batch of a shade you can't get. The dry chips will show how different some of them will look when dry. Always mix *wet* paint to match a *wet* sample.

These Navy paints are by far and away the best that money can buy. Most of the Navy stock is manufactured in the Navy's own factories at Norfolk and Mare Island. *The paint must be mixed well or shaken up well.* These paints are made to the right consistency to go through *clean* repeat clean spray guns under normal air pressure and give the best possible protective coating. Average spray guns require 50 to 65 pounds.

With clean spray guns the paint will not require much thinner. Generally never use more than one pint of thinner to 5 gallons of paint. When paint becomes old it may solidify in the can and cannot be used. Solidified paint should be returned to the factory where it can generally be reworked.

TABLE OF PAINTS LISTED IN SEQUENCE FROM LIGHTEST TO DARKEST

| Name | Formula | Stock No. | Key number used on diagrams | Reflectance in percent | Specification |
|------------------------------------------------------------------------|---------|---------------|-----------------------------|------------------------|---------------|
| Glossy White—use on over-heads only. | 6 | G52-P-5305 | GW | 80-85 | MIL-P-1264. |
| White Flat | 5 U | G52-P-5335 | W | 76-82 | JAN-P-1114. |
| Outside Gray number 46 | 46 | G52-P-5083-5 | 46 | 44-48 | MIL-P-15182. |
| Light Gray | 5 L | G52-P-962 | 37 | 36-38 | MIL-P-15181. |
| Haze Gray | 5 H | G52-P-961 | 27 | 27-28 | MIL-P-15130. |
| Ocean Gray | 5 O | G52-P-965 | 17 | 16-17 | MIL-P-1265. |
| Outside Gray number 11 | 109 | G52-P-5086-5 | 11 | 10-11 | MIL-P-15183. |
| Navy Gray | 5 N | G52-P-963 | 7 | 6-7 | MIL-P-15129. |
| Black (dull) | 104 | G52-P-5075 | DB | 3-4 | MIL-P-15146. |
| *Deck Paint Mixture 1 part of Navy Gray and 5 parts of Black Striping. | | | M | 2 | |
| Black Striping | 38 | G52-P-7810-20 | GB | 1 | 52-P-36. |

*Deck Paint mixture is not yet listed in Navy Stock Catalogues and must be mixed by the users: Add one gallon of Navy Gray that has been well stirred to a 5-gallon pail of Black Striping. Stir well.

| Standard Navy stock No. | Name and description | SS | AS |
|-----------------------------------------------------------------------------------------|--------------------------------------------------------------------------------------------------------------------------------------------------------------------------------------------------------------------|-------|-------|
| 40-S-2590-20 for vessels with AC current or 40-S-2590-21 for vessels having DC current. | Paint sprayer outfit, lightweight, type B consisting of light duty touch-up gun, pressure cup, air hose, air compressor, compressor motor and air pulsation tank, or chamber AC or DC (Spec. MIL-S-15297, type B). | ----- | 2 |
| 40-S-2590-19----- | Paint spray outfit, type A consisting of heavy duty spray gun, 5-gallon pressure tank, 1-quart pressure cup, two 25-foot lengths material hose, two 25-foot lengths air hose (Spec. MIL-S-15297, type A). | ----- | 2 |
| 40-T-40-2123----- | 2-gallon pressure tank (Spec. MIL-S-15297, type A)----- | 1 | ----- |
| 40-G-513-1150----- | (2) Heavy duty spray gun with removable 1-quart pressure type cup with lid and 1 extra cup without lid (Spec. MIL-S-15297, type A) 2 guns with 4 cups. | 2 | 2 |
| 40-G-513-1630----- | Heavy duty spray gun with one 6-foot extension handle and one 8-foot extension handle (Spec. MIL-S-15297). | *1 | 2 |
| 33*-H-461----- | 25-foot lengths material hose with suitable fittings attached-- | 2 | ----- |
| 33-H-640-9950 (3/8 inch coupling and connector) 40-A-27-565 (1/4 and 3/8 inch adapter). | 25-foot lengths air hose with suitable fittings attached----- | 8 | 8 |
| 40-M-2875----- | Paint mixing attachment for use with electric or pneumatic drill. | ----- | 2 |
| Procurable through BuShips----- | Paint conditioning machine (mechanical agitator or shaker)----- | ----- | 1 |

* Only for submarines equipped with hangars.
Paint sprayers and mixers should be listed in Group S92—Part I.



Order by stock numbers. See page 14 for paints used on landing craft.

If there is occasion to report a batch of paint wrongly labeled or so old that it has solidified, all of the numbers on the can including the batch number, date, and manufacturer's name should be noted in the report.

Navy stock catalogs are adding several items of spray painting equipment including parts and maintenance kits. Watch for these additions.

The ship's allowance lists for submarines and submarine tenders are being increased as shown on the preceding table. Other ships allowances remain the same.

For instruction on use, care, and maintenance of spray guns and other spray painting equipment, see U. S. Navy Damage Control Manual NavPers 10571.

There are several different types of spray guns. Some are limited to just one spray pattern while others have an adjustable nozzle that can be set for a round blast, or sheet spray. The sheet spray can be set across or up and down. Most modern guns have a removable spray head assembly. These are more easily cleaned than the older types and have other advantages.

Either suction feed cups or pressure feed cups can be used for outside ship paints, but the *pressure* feed cup type generally works best for *heavy paints*, and the suction feed cup type is handier for light-weight materials such as lacquers and thin primary coats in house painting.

This pressure feed cup type is the outfit most suitable and the one likely to be issued to submarines. See Damage Controlman 3-2 Manual (NavPers 10571).

